

你的意识自带升级功能

用了几十年

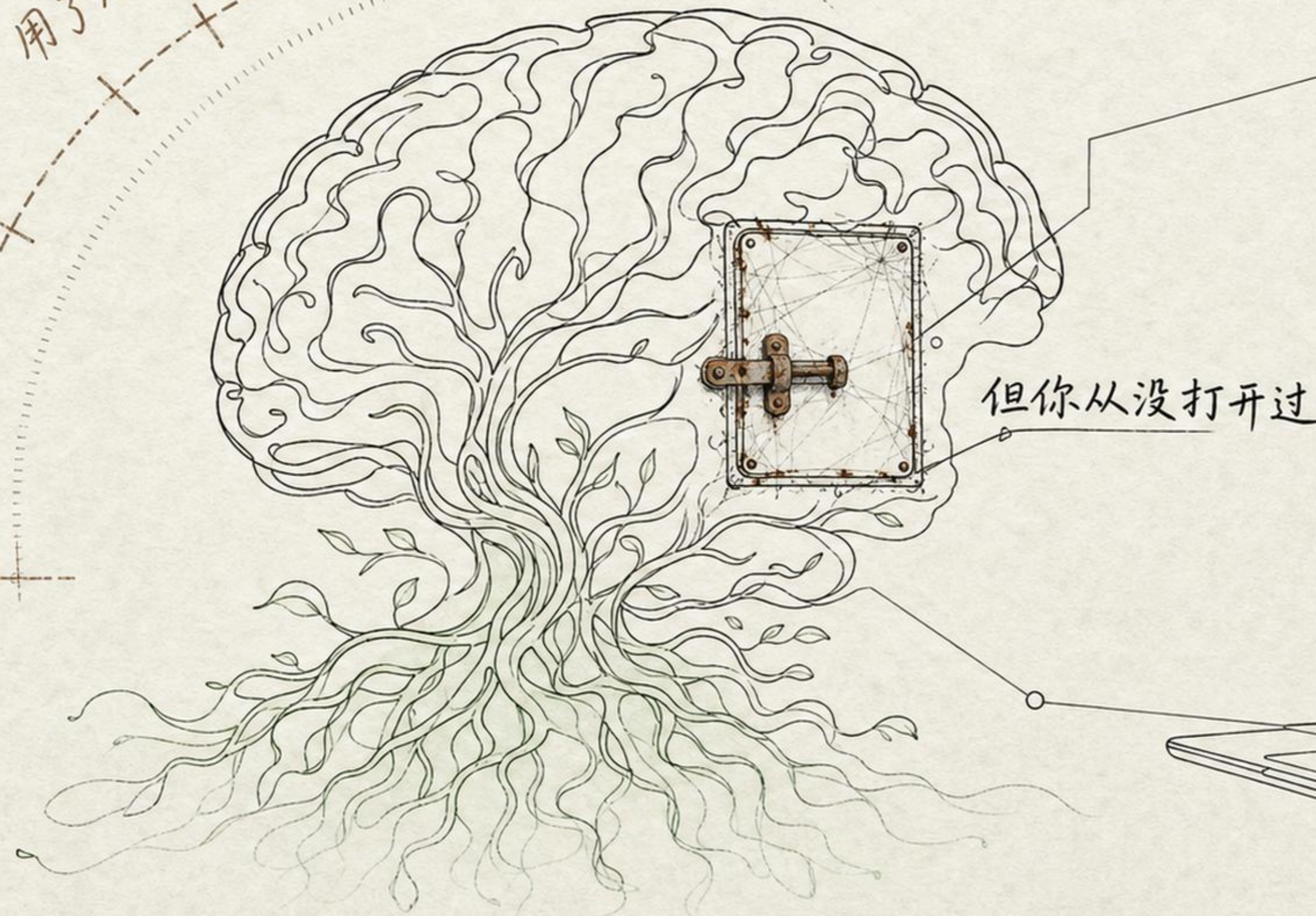

但你从没打开过

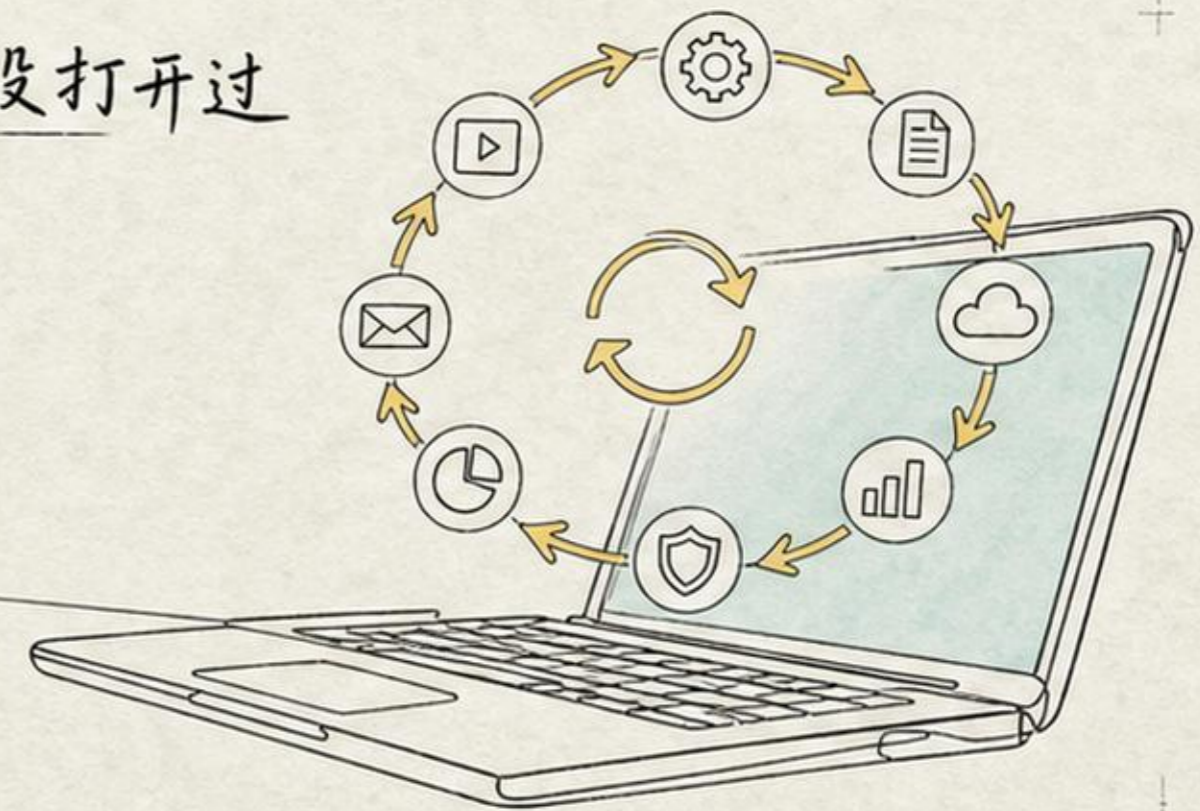

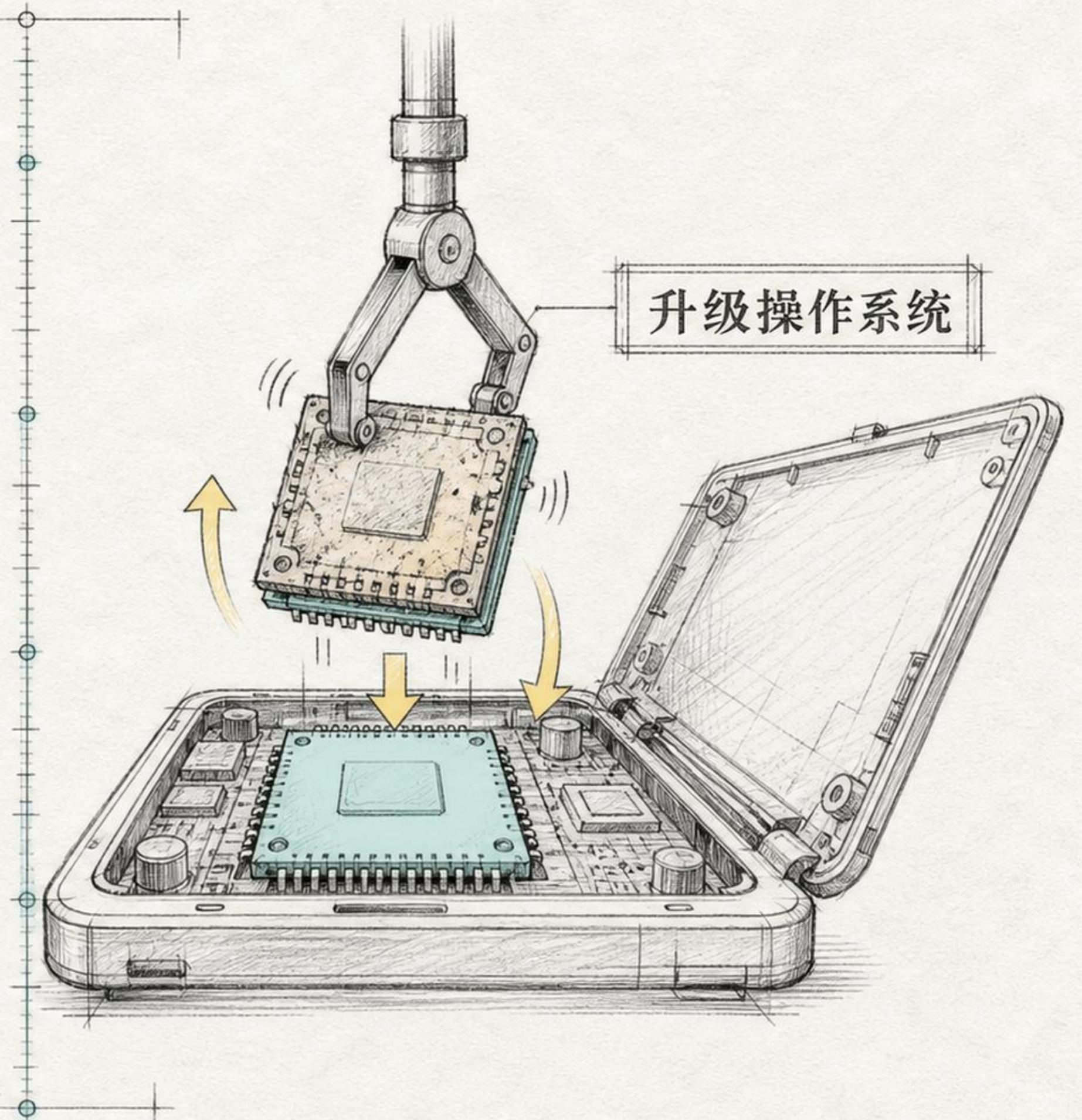
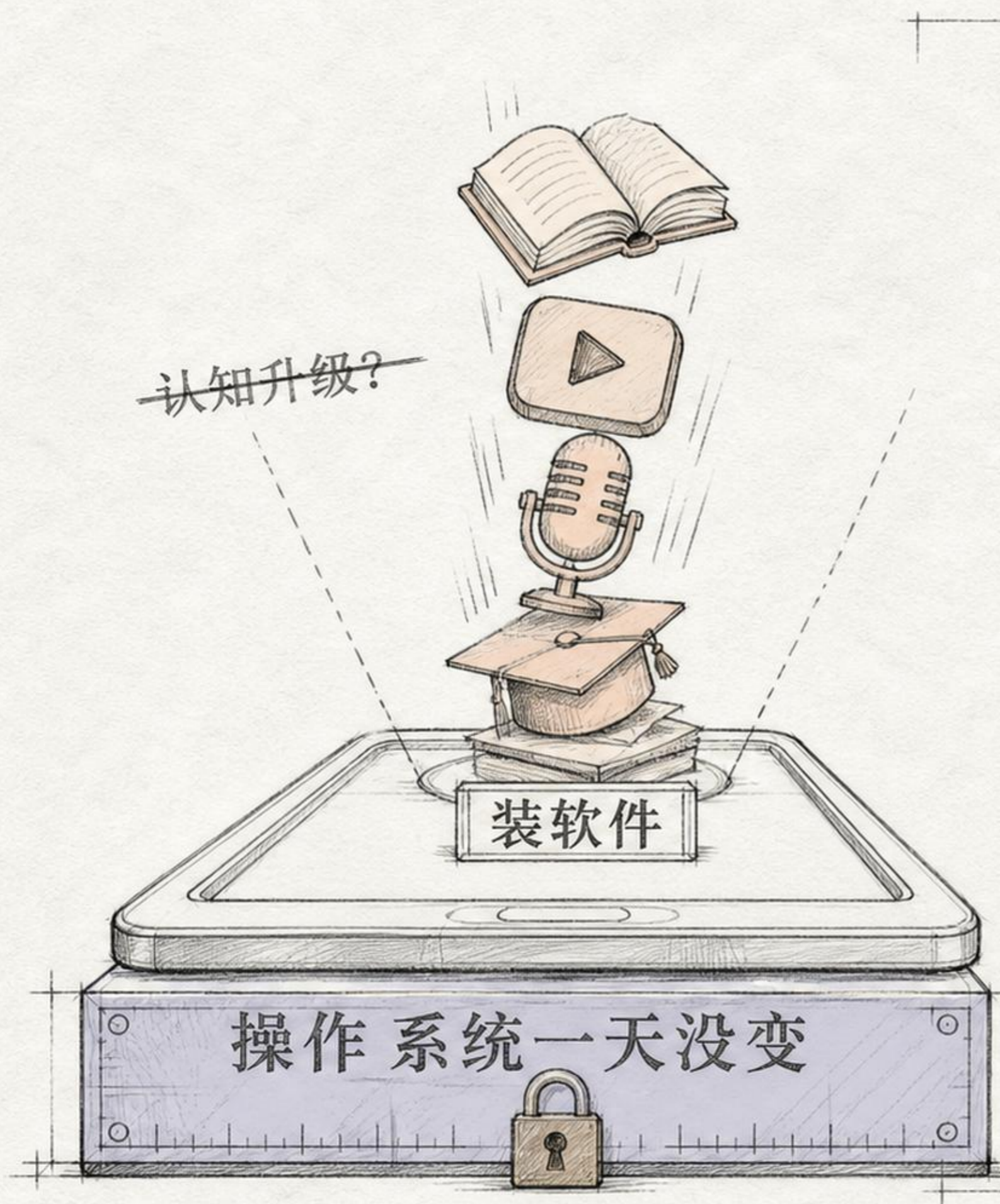

成唯识论 · 最后一期

王利杰

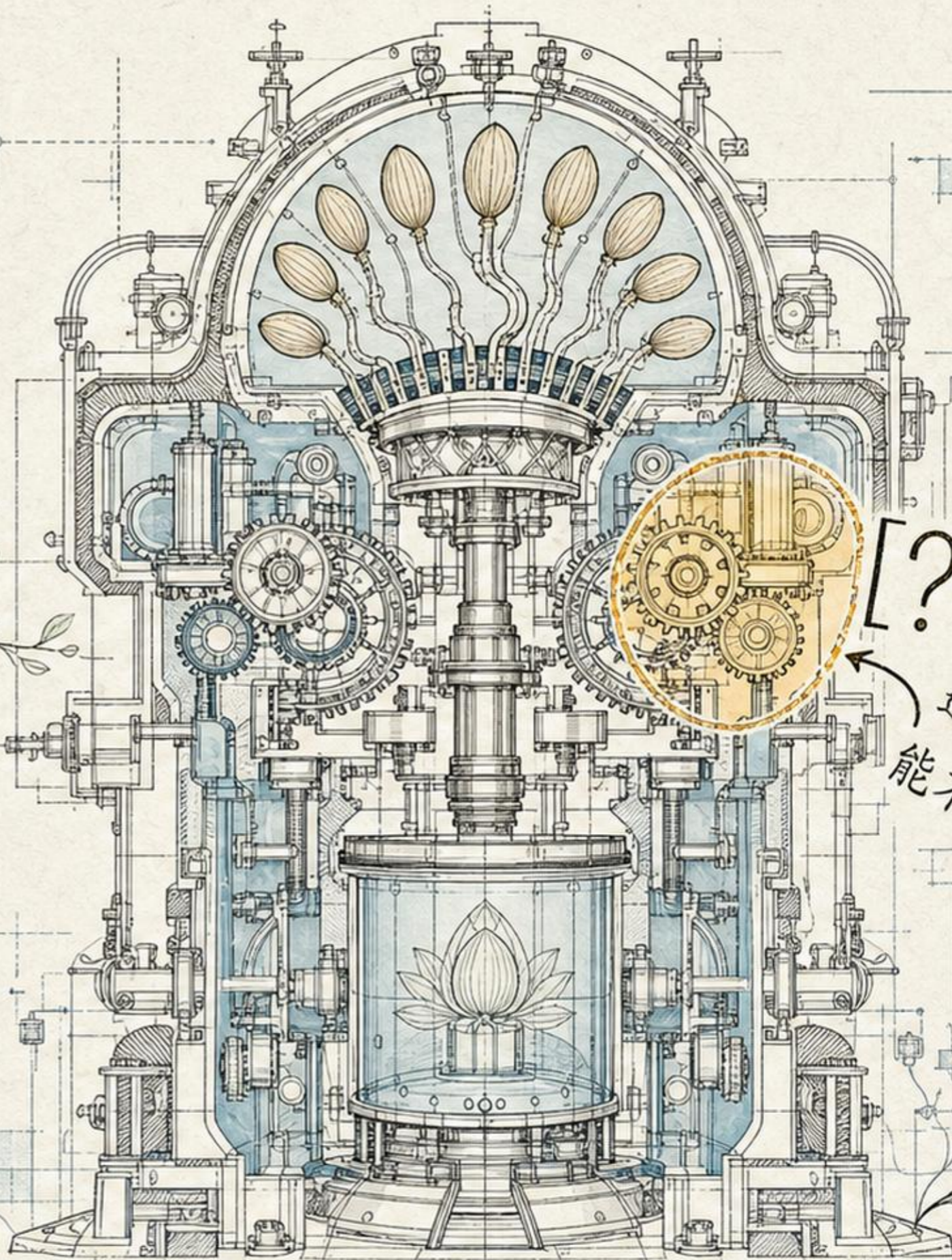

[?]
这台发动机，
能不能改装？



改装手册

转识成智

把识转成智

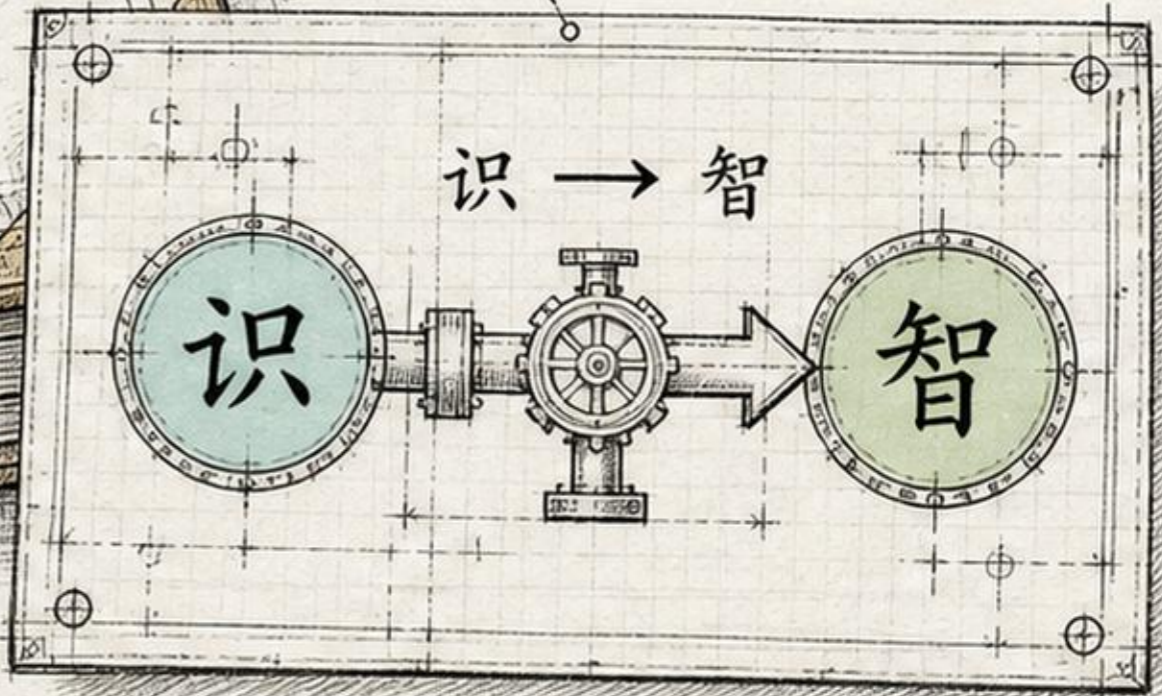

~~不是从无知变有知~~

~~也不是愚蠢变聪明~~

底层运作模式

从根本上切换

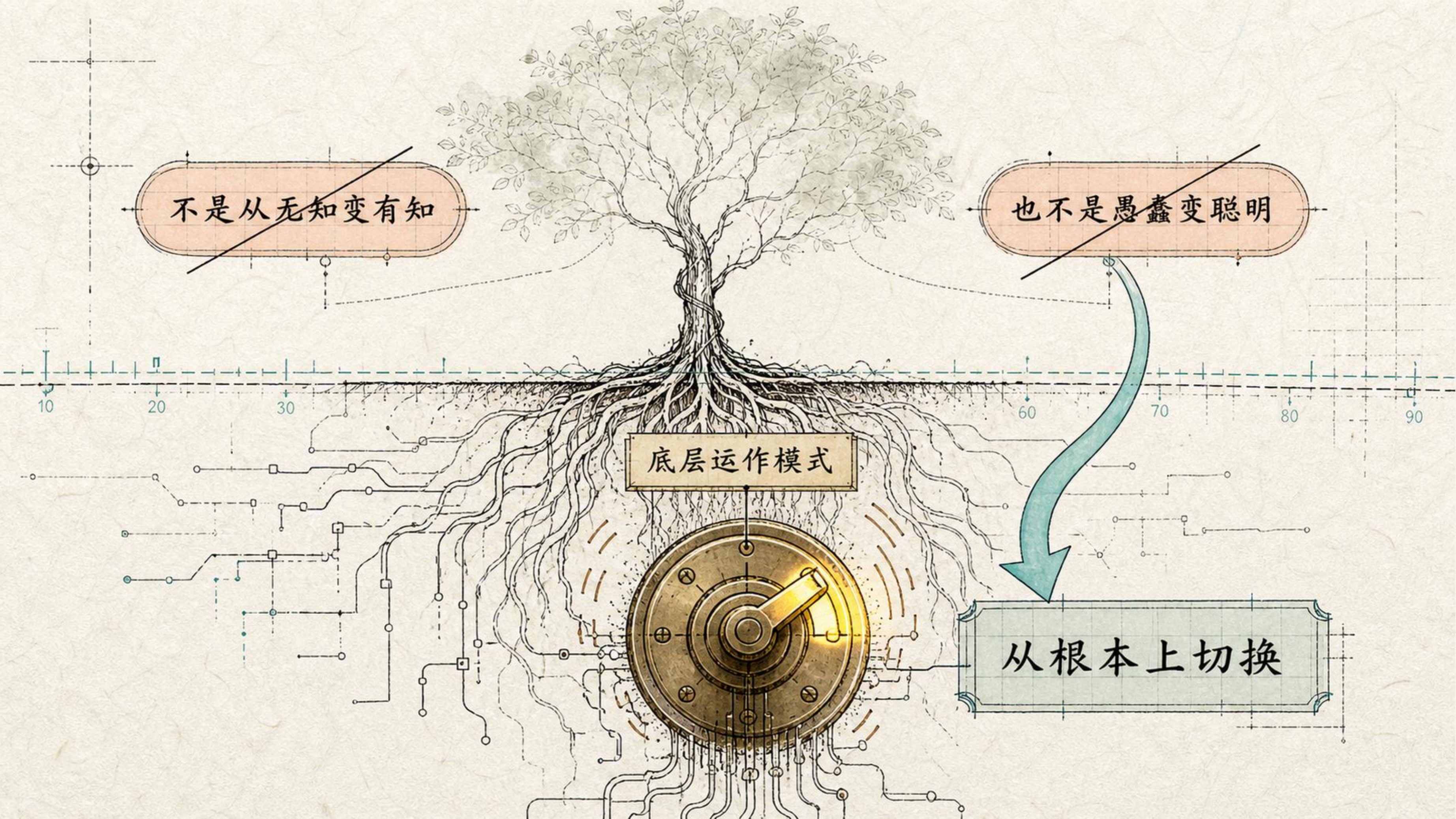

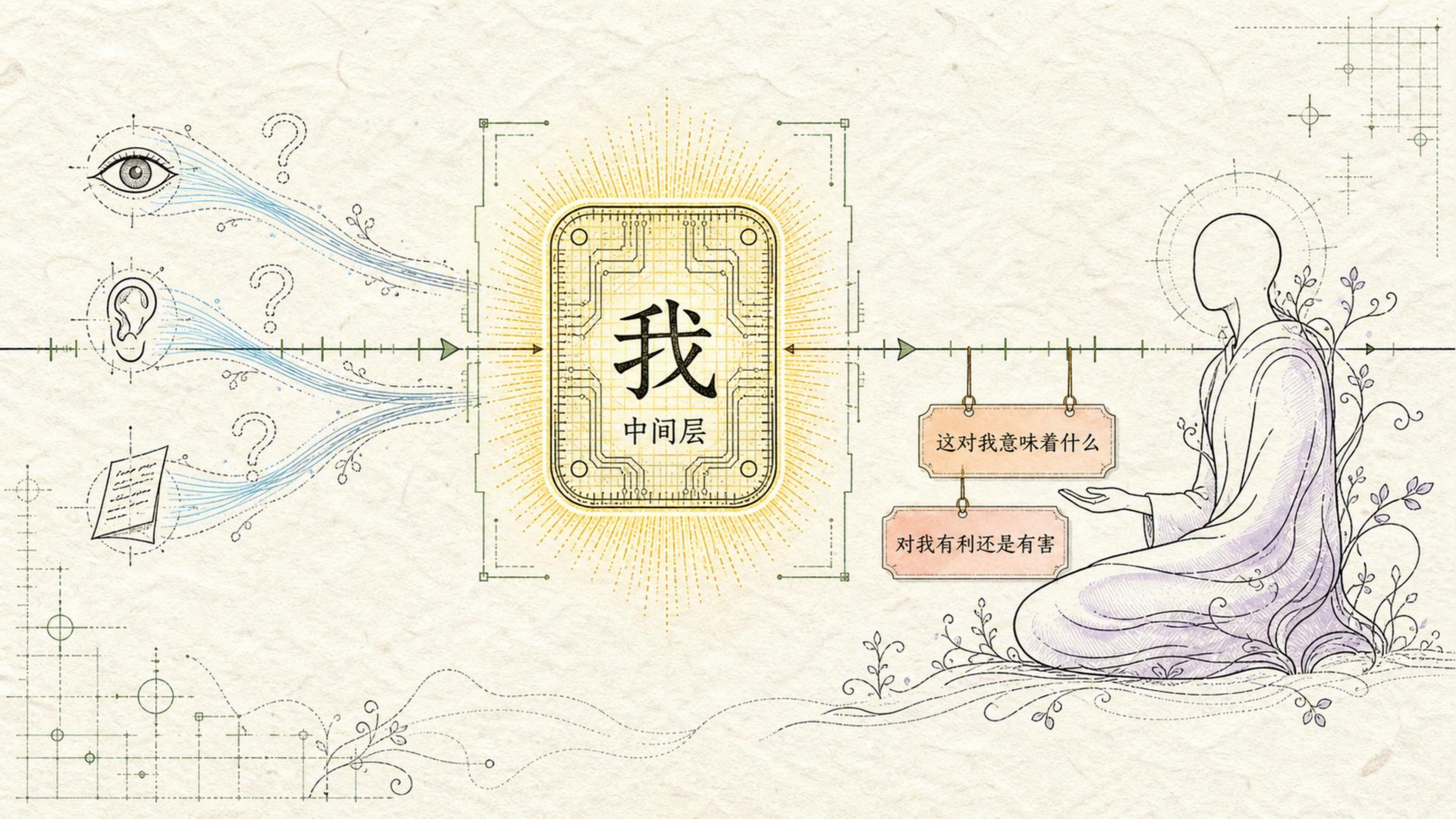

我

中间层

这对我意味着什么

对我有利还是有害

第七识·末那识

这是我的手

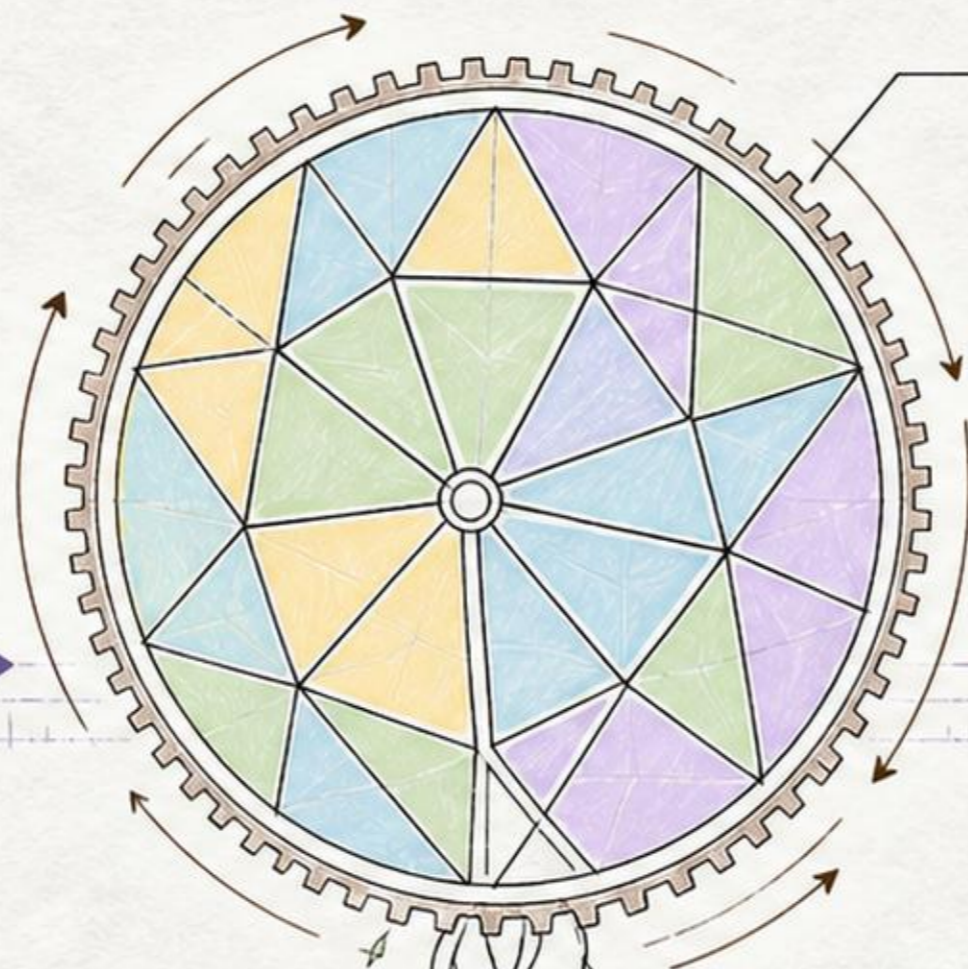

自我滤镜



染上颜色再交给你

10

20

30

70

80

90

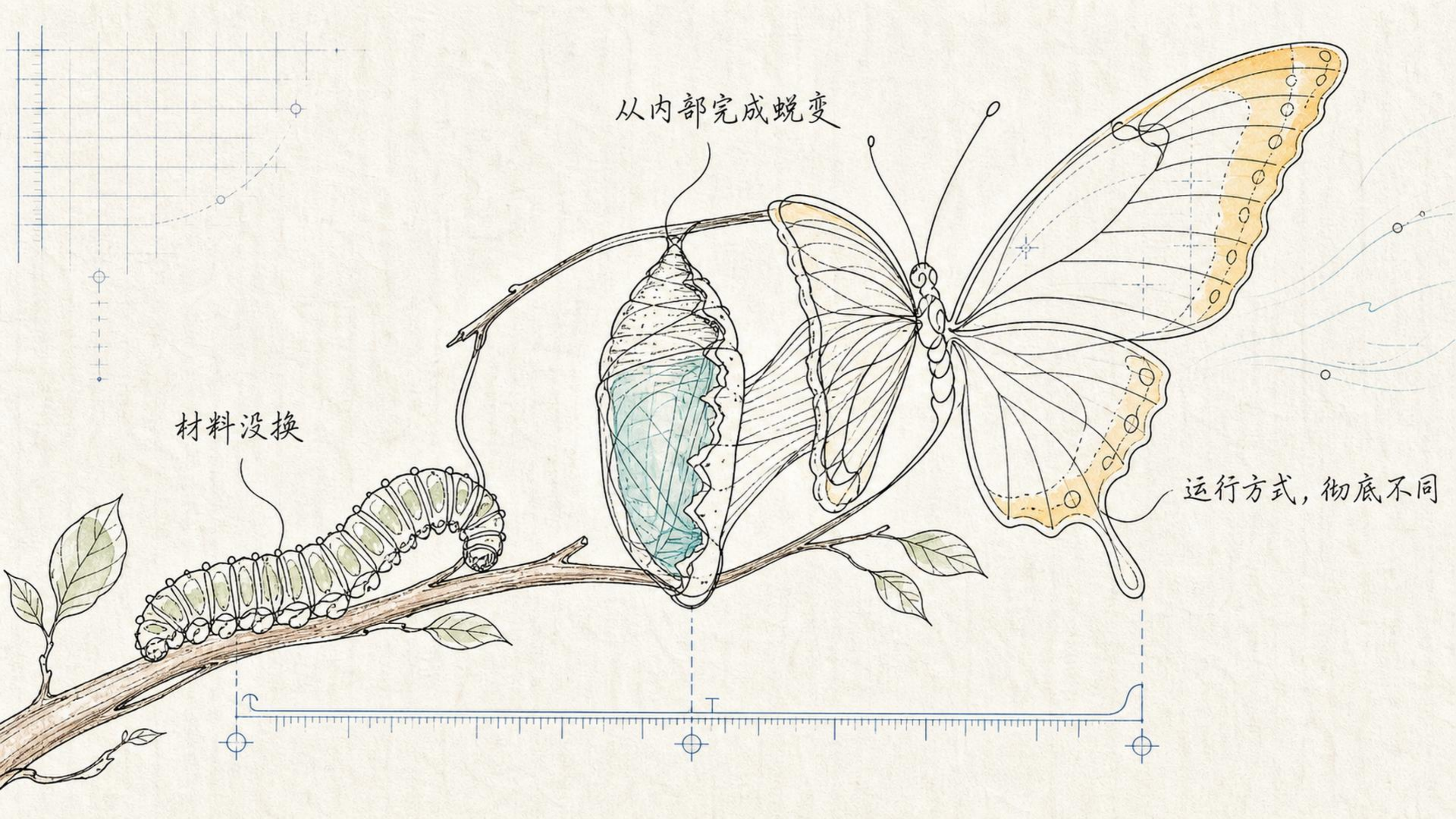

从内部完成蜕变

材料没换

运行方式, 彻底不同

八个识，转出四种智慧

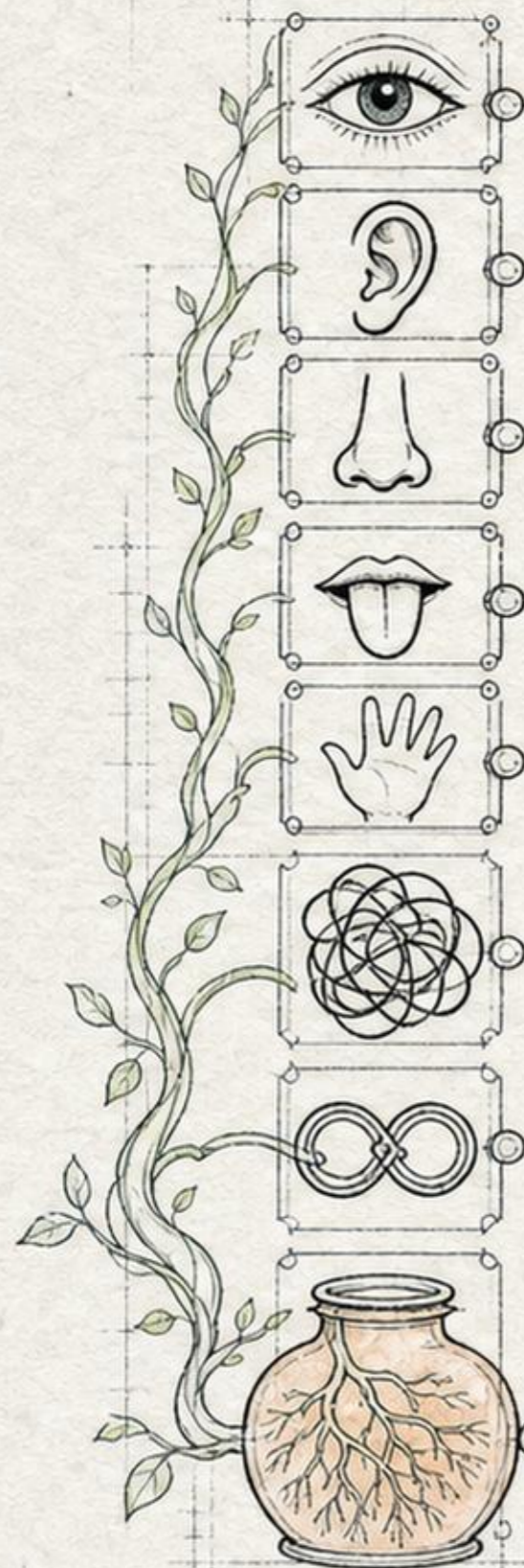

前五识 · 第六识 · 第七识 · 第八识

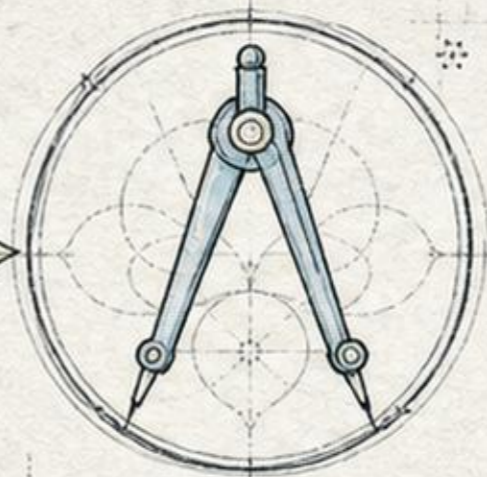

成所作智 · 妙观察智

平等性智 · 大圆镜智

前五识 · 眼耳鼻舌身

被动接收 → 精确工具

成所作智

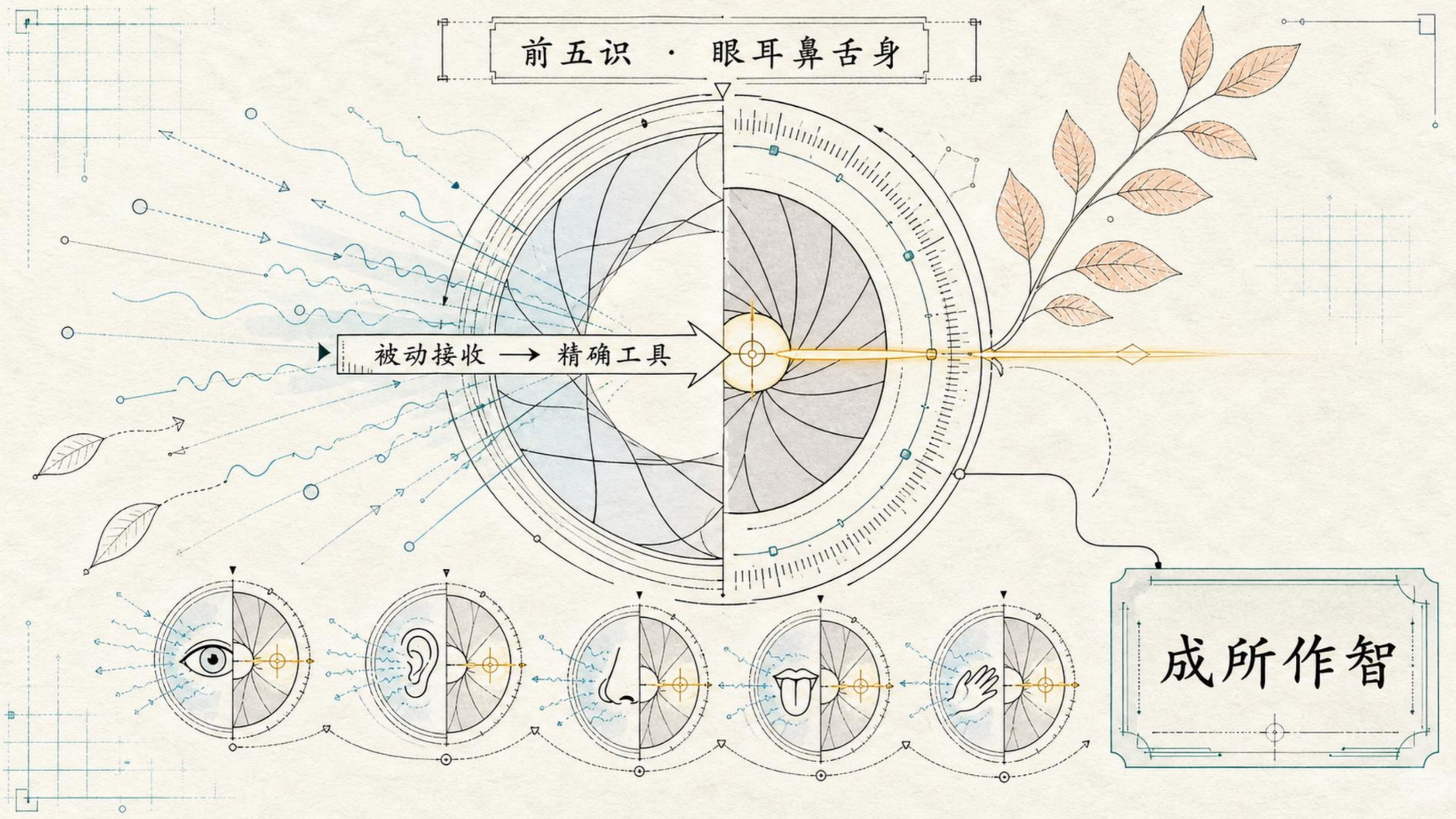

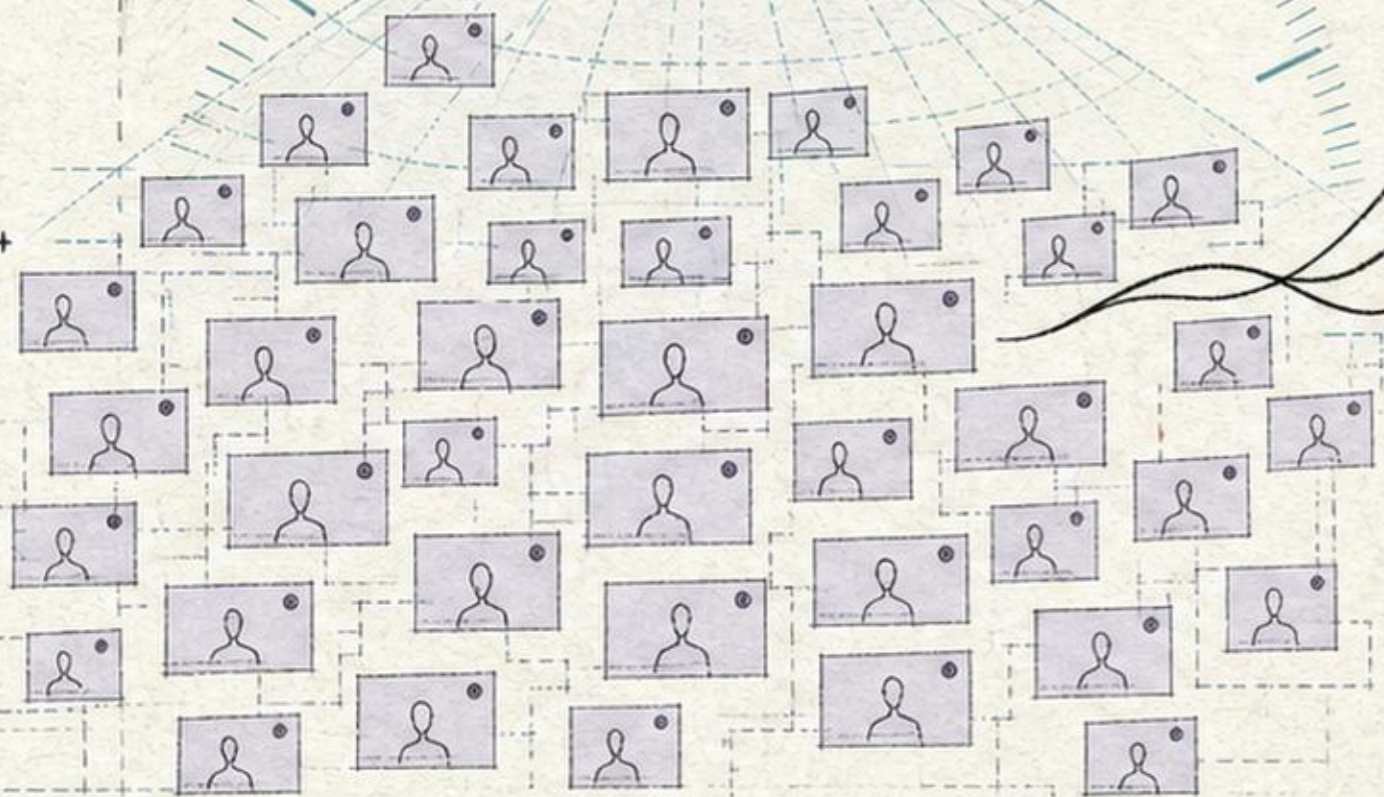
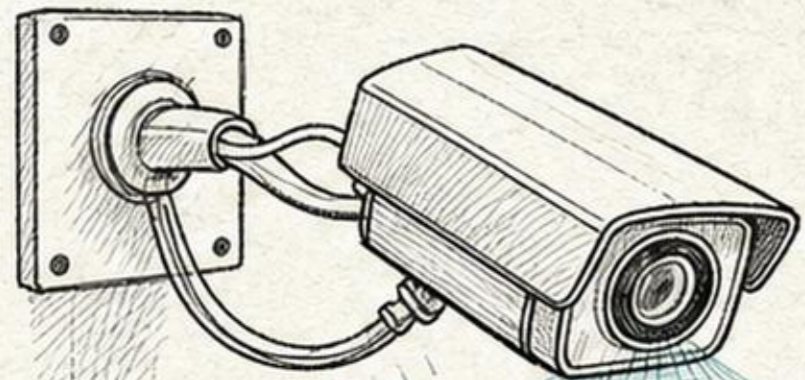

普通感官 = 监控摄像头

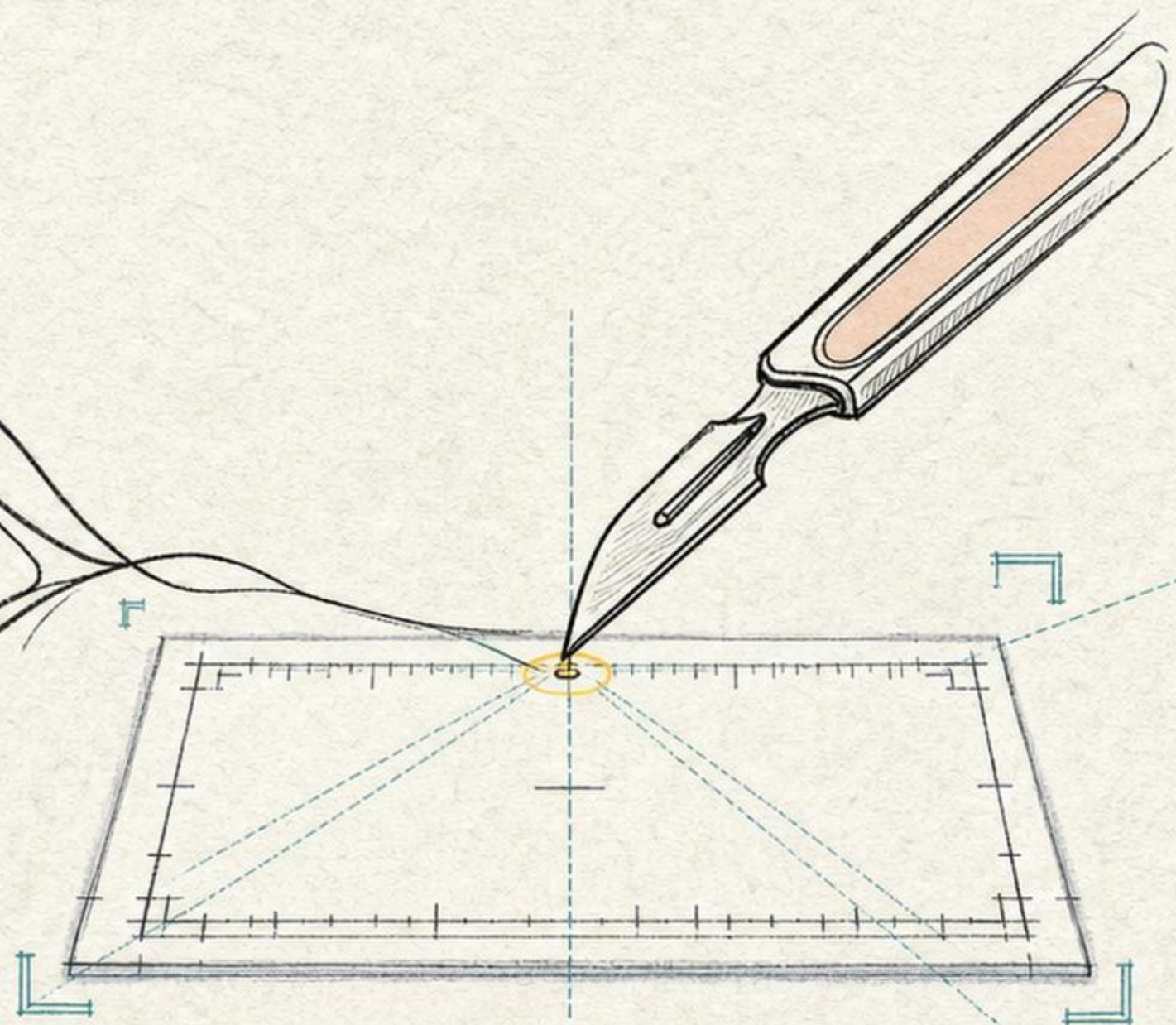
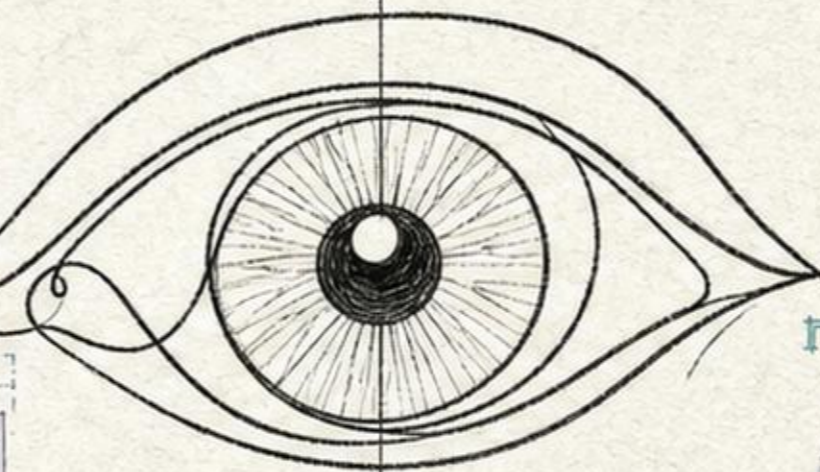

转智之后 = 手术刀

同样的器官，精度完全不同

第六意识

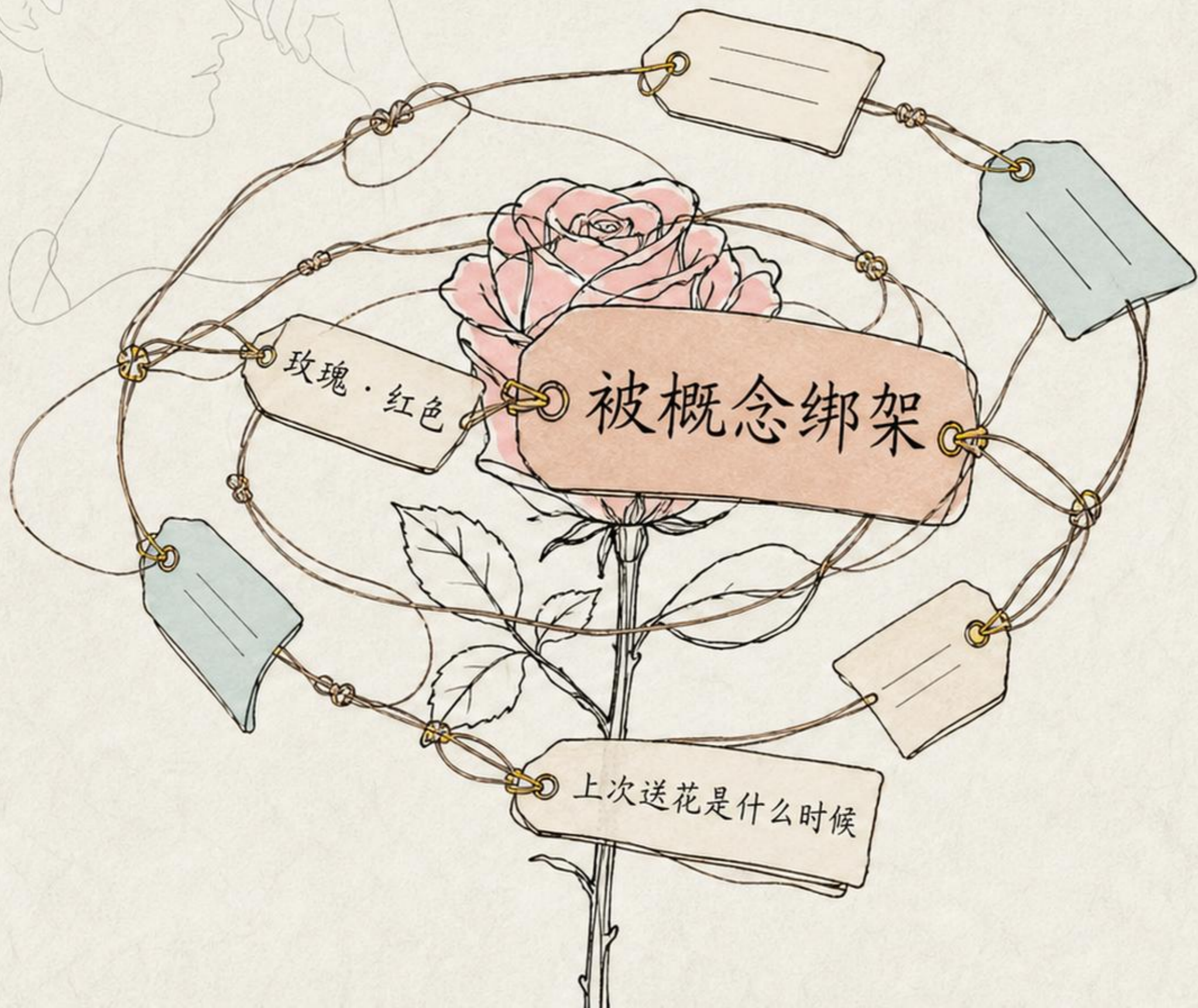

标签

分类

框架

妙观察智

如实地看到当下的样子。

玫瑰

光

光在花瓣边缘跳舞

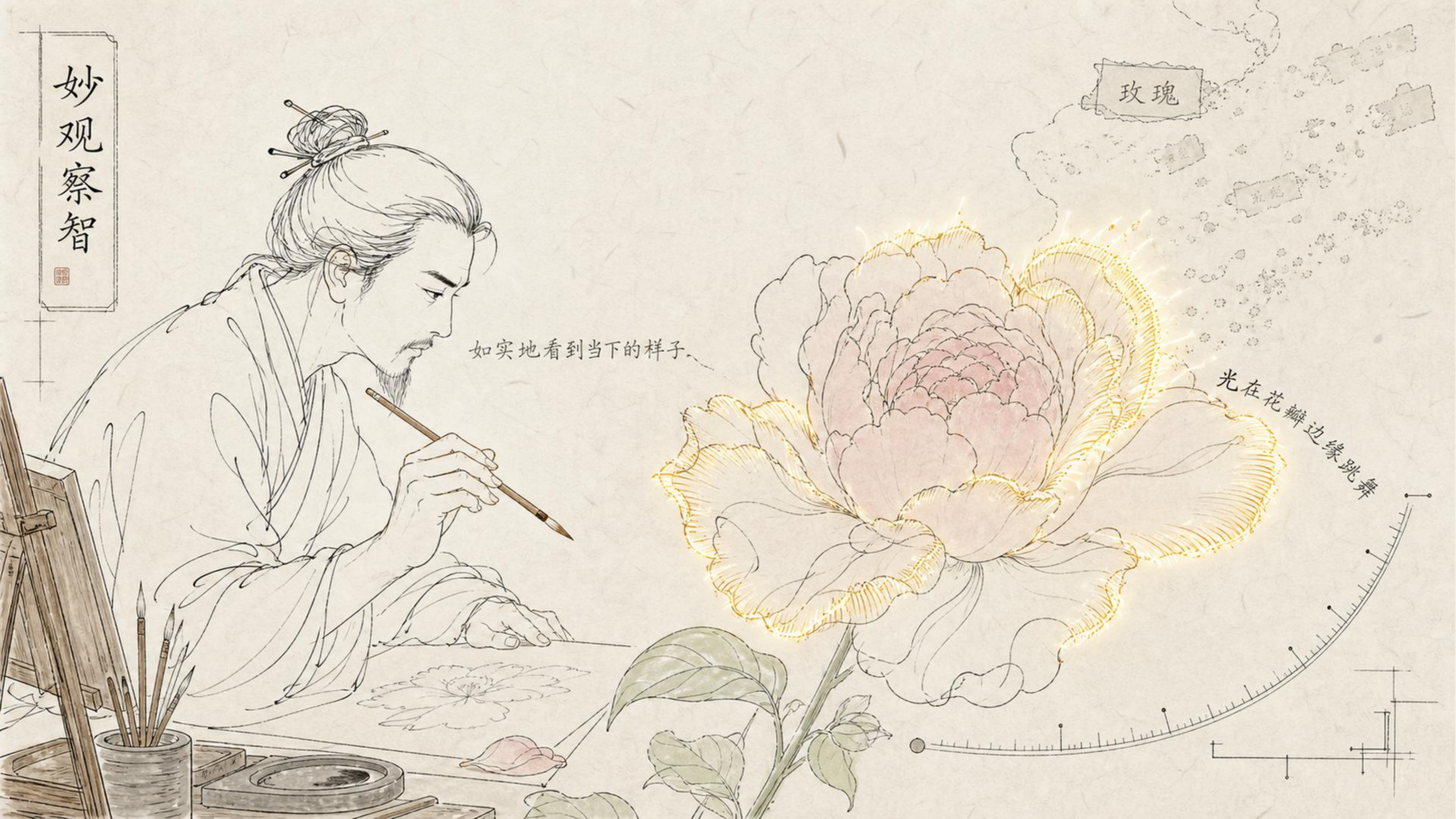

末那识 → 平等性智

我的

不是我的

裂缝愈合

一样的重量

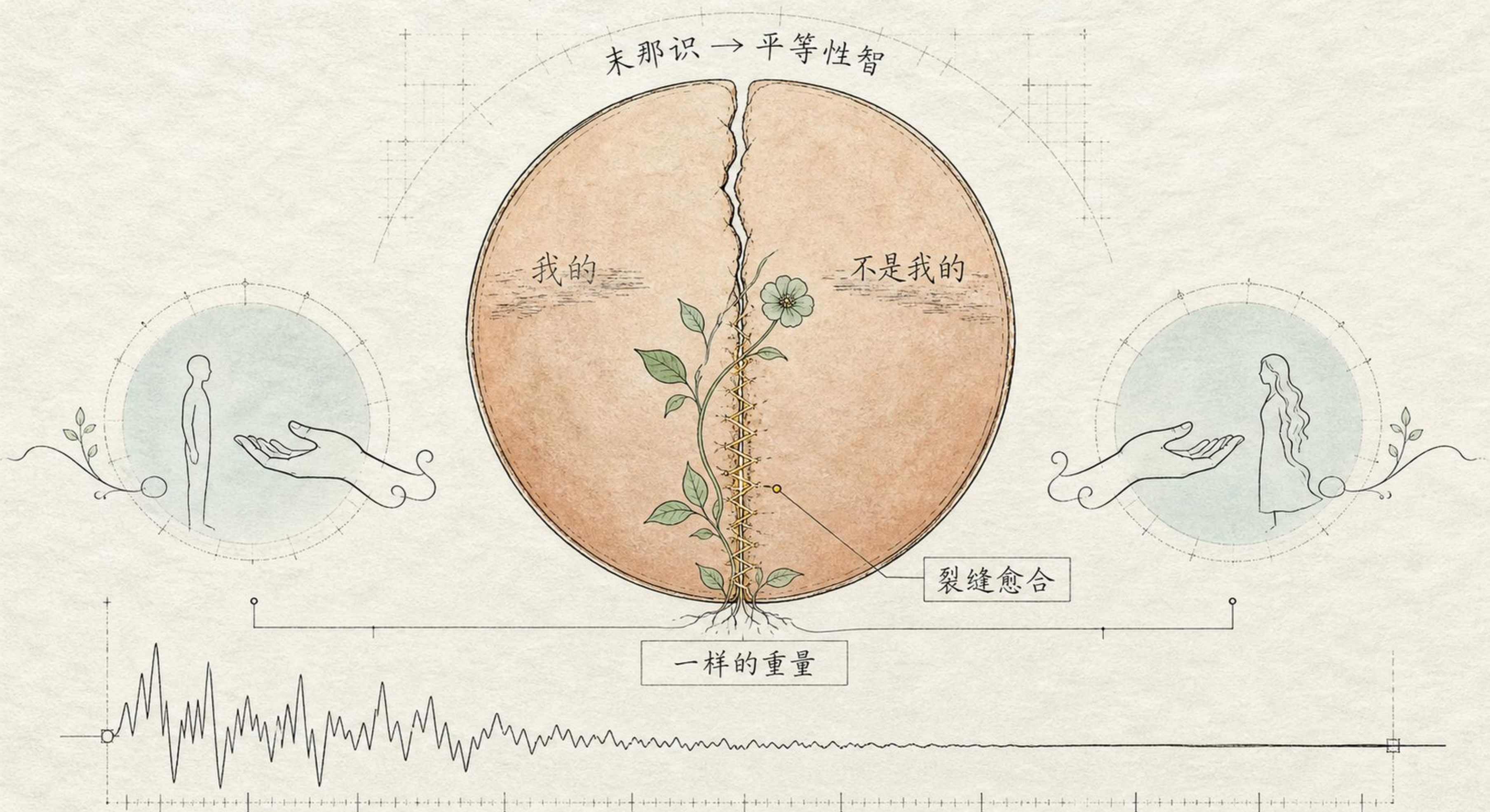

不是变得无感



什么都映照

擦干净的镜子

不说这是我的影子

阿赖耶识 → 大圆镜智

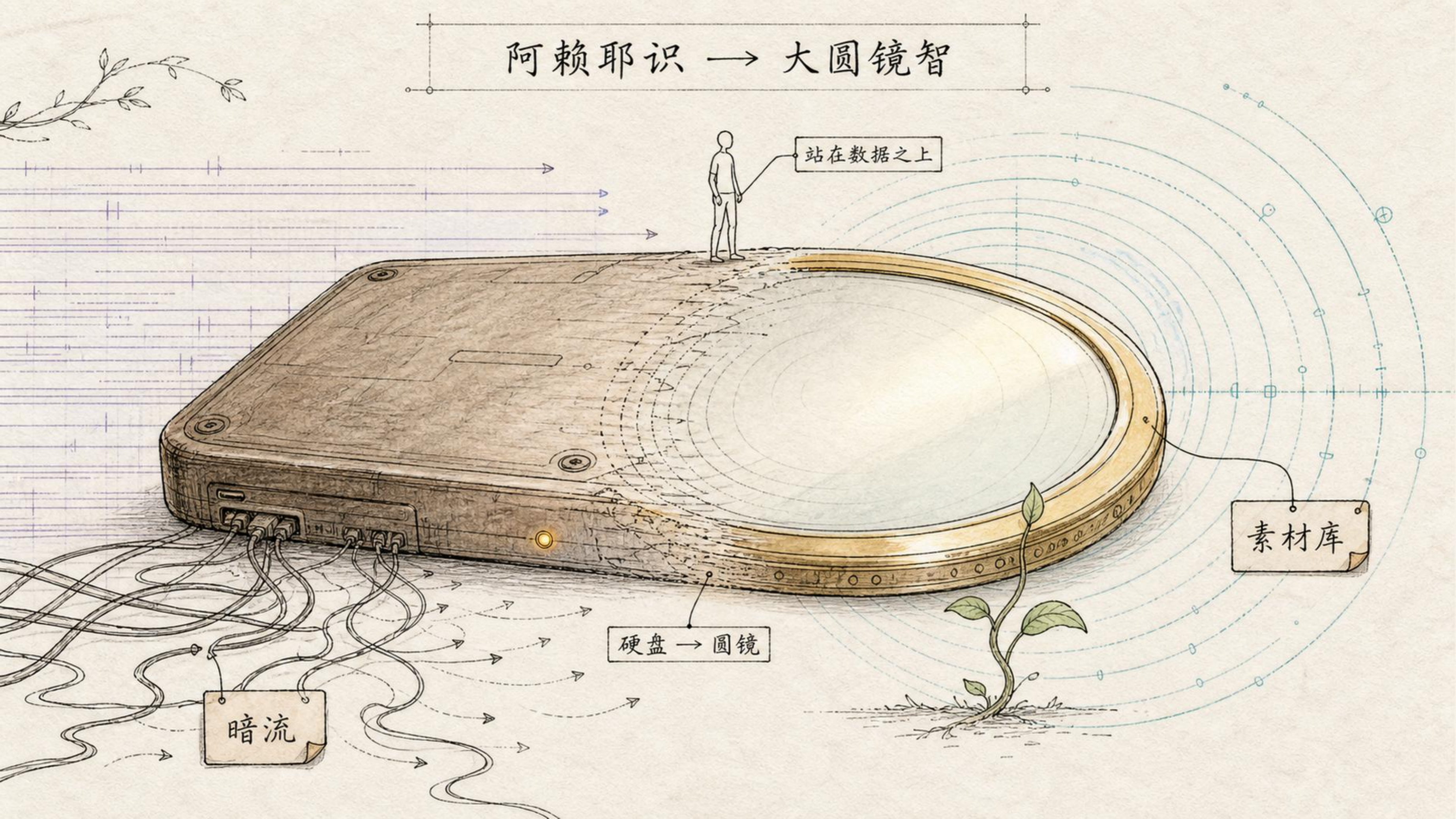

站在数据之上

素材库

硬盘 → 圆镜

暗流

五位修行

资粮 · 加行 · 通达 · 修习 · 究竟

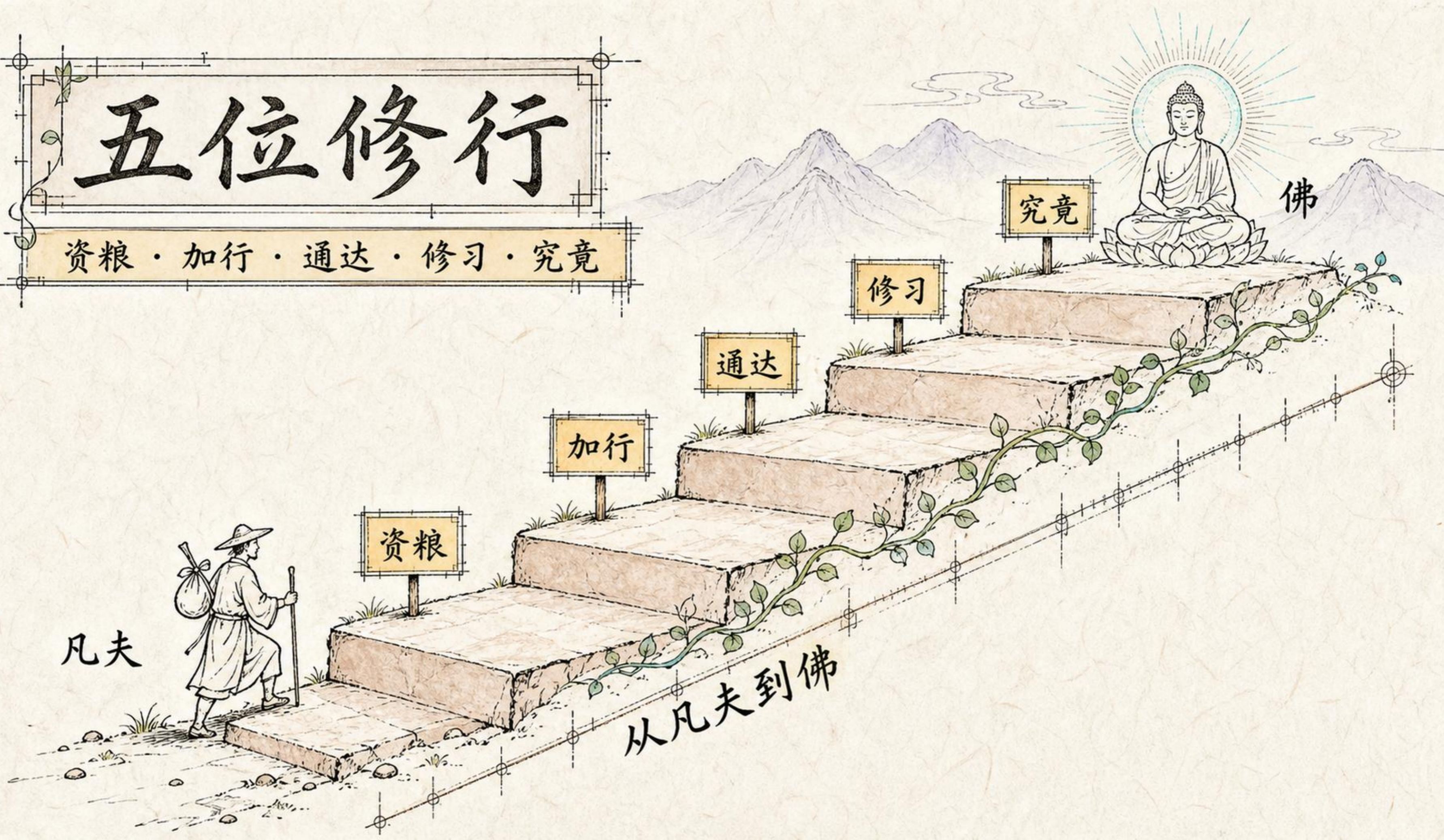

凡夫

从凡夫到佛

资粮位



知道，但做不到



读经

持戒

禅定

布施

攒粮食，还没出发

起点

陷阱：知识 ≠ 上路

看了一百期视频，
道理都懂，
生活还是一团糟

隔着的是
操作系统的切换

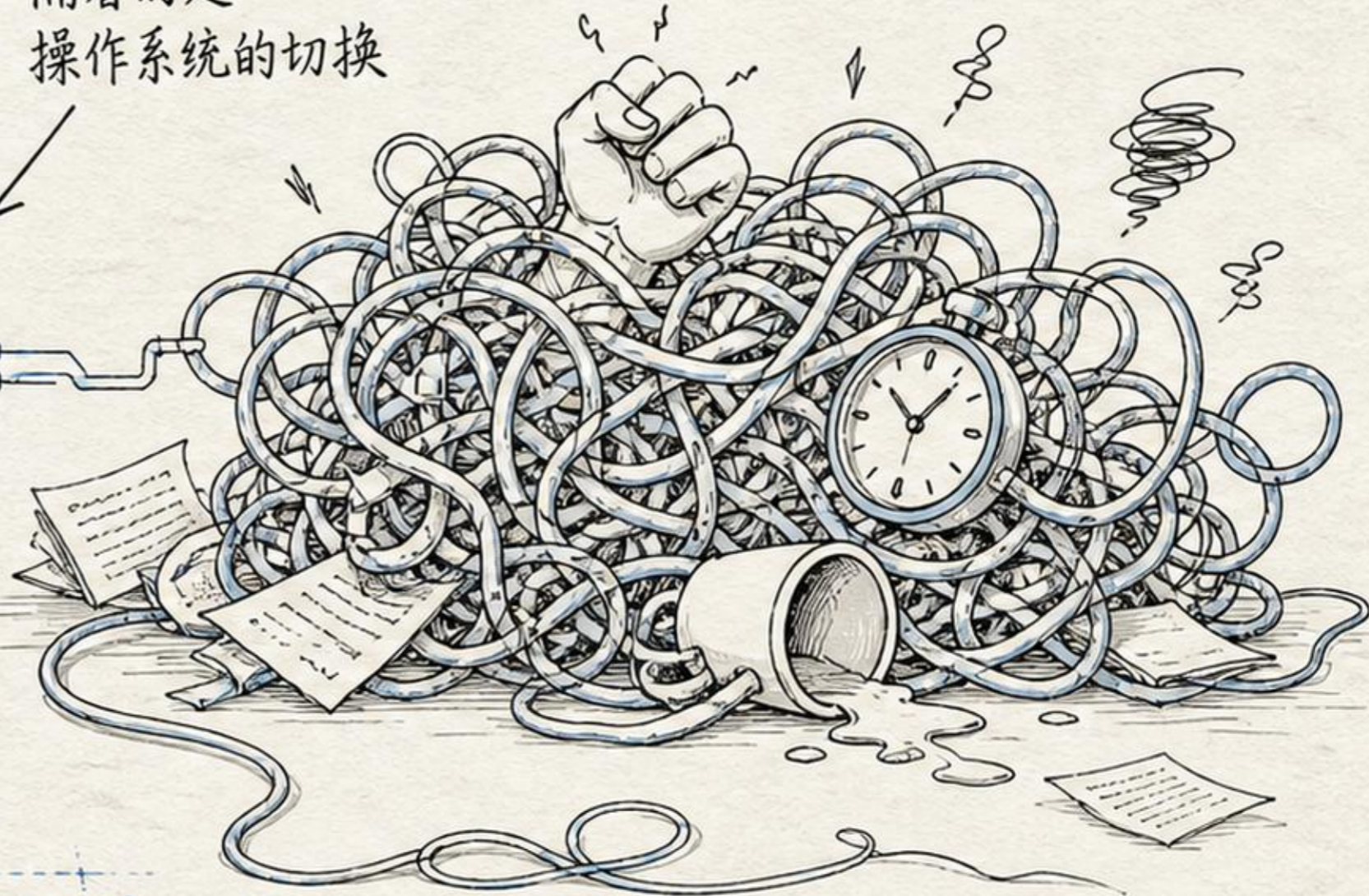

加行位

亲眼看见念头升起

我

「我的」戳

我

末那识

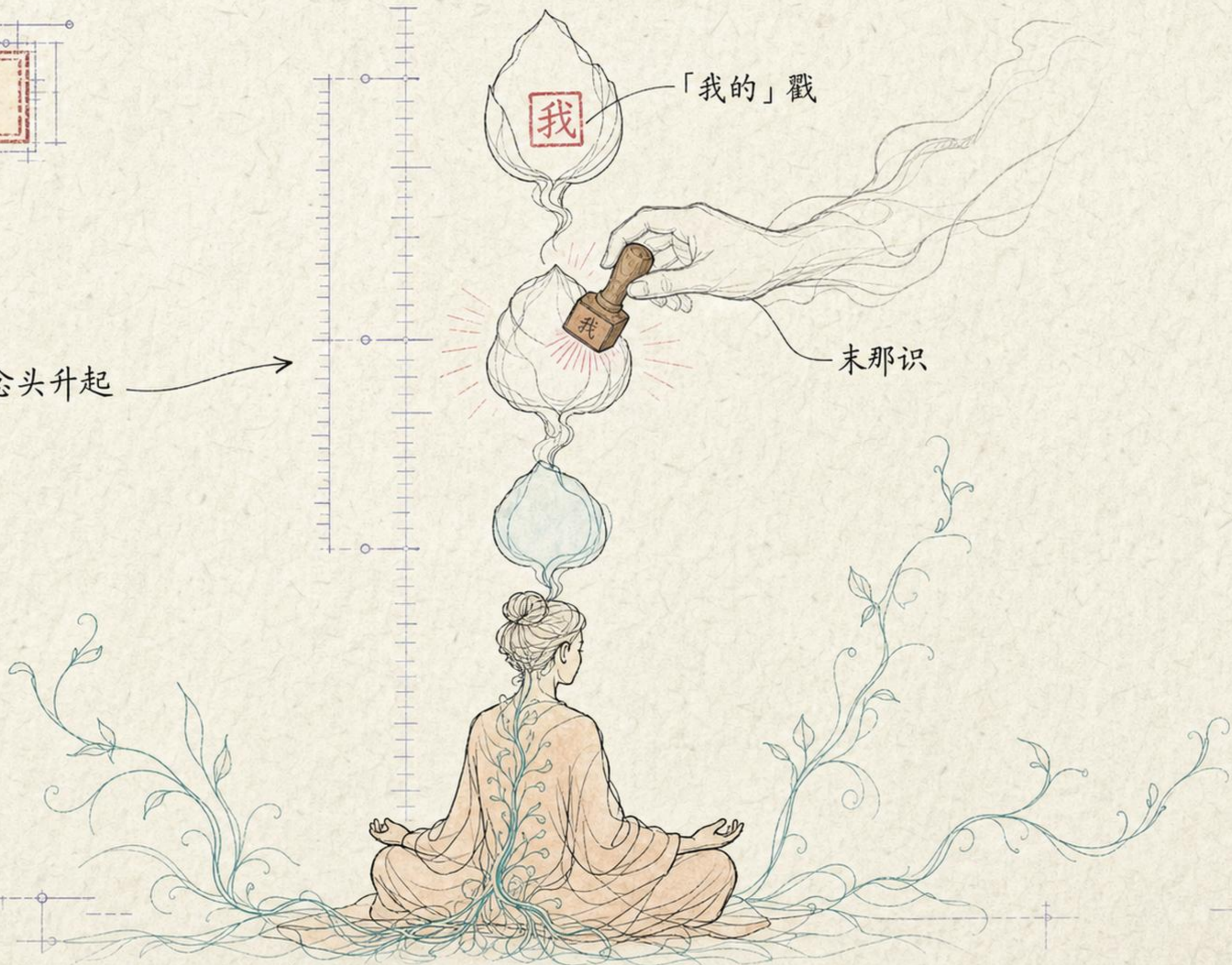

暖·顶·忍·世第一法



暖·靠近火源



顶·凡夫天花板



忍·承受冲击



世第一法·世间最远处

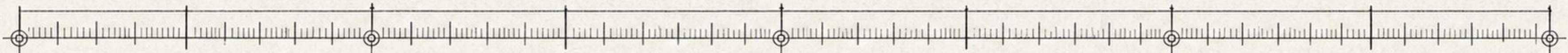

通达位·见道

亲眼见到真如

读大海的书 → 站到海边



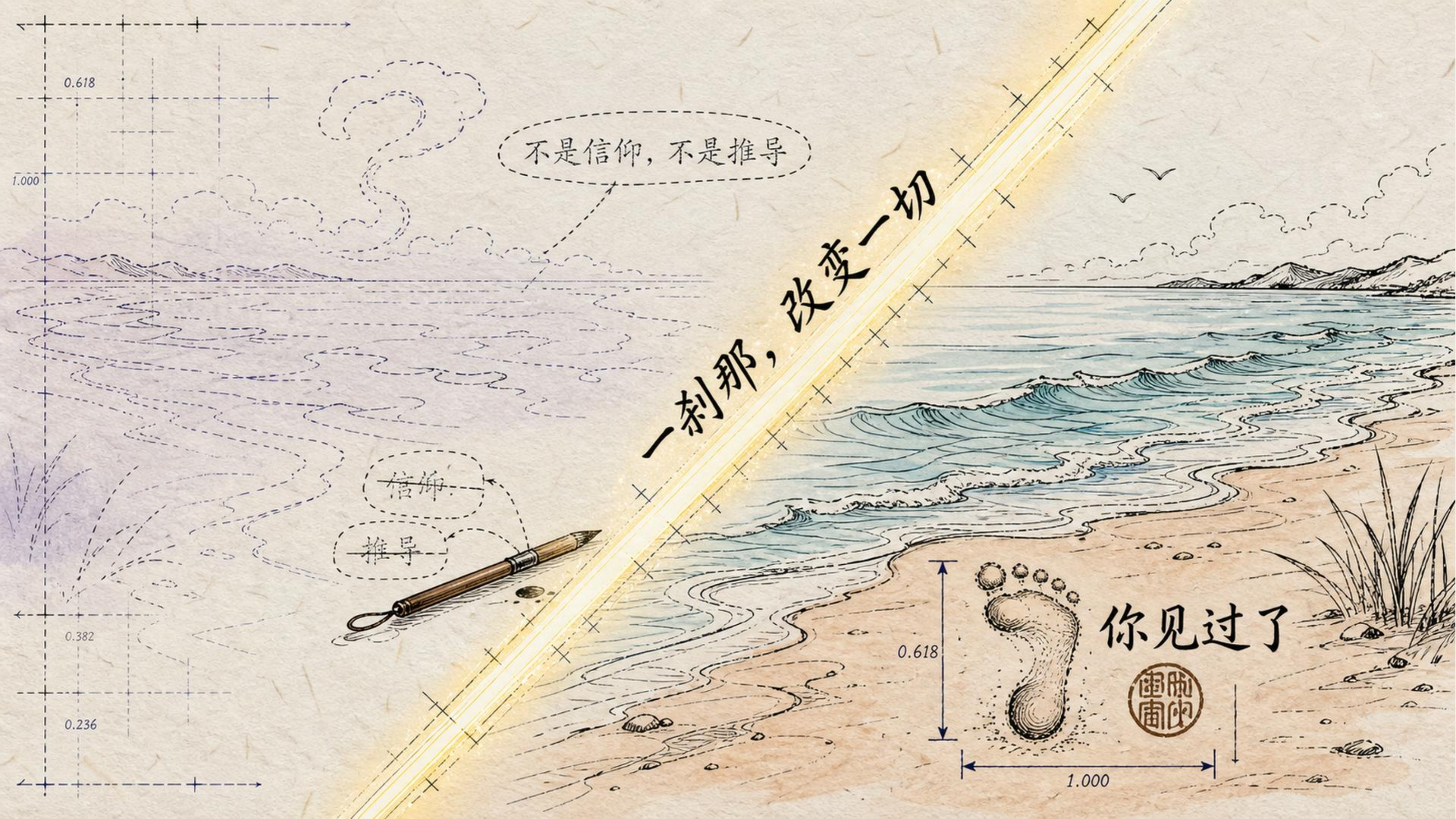

不是信仰，不是推导

一刹那，改变一切

信仰

推导

你见过



0.618

1.000

0.618

1.000

0.382

0.236

修习位

见道之后是开始

让光照进每一个角落

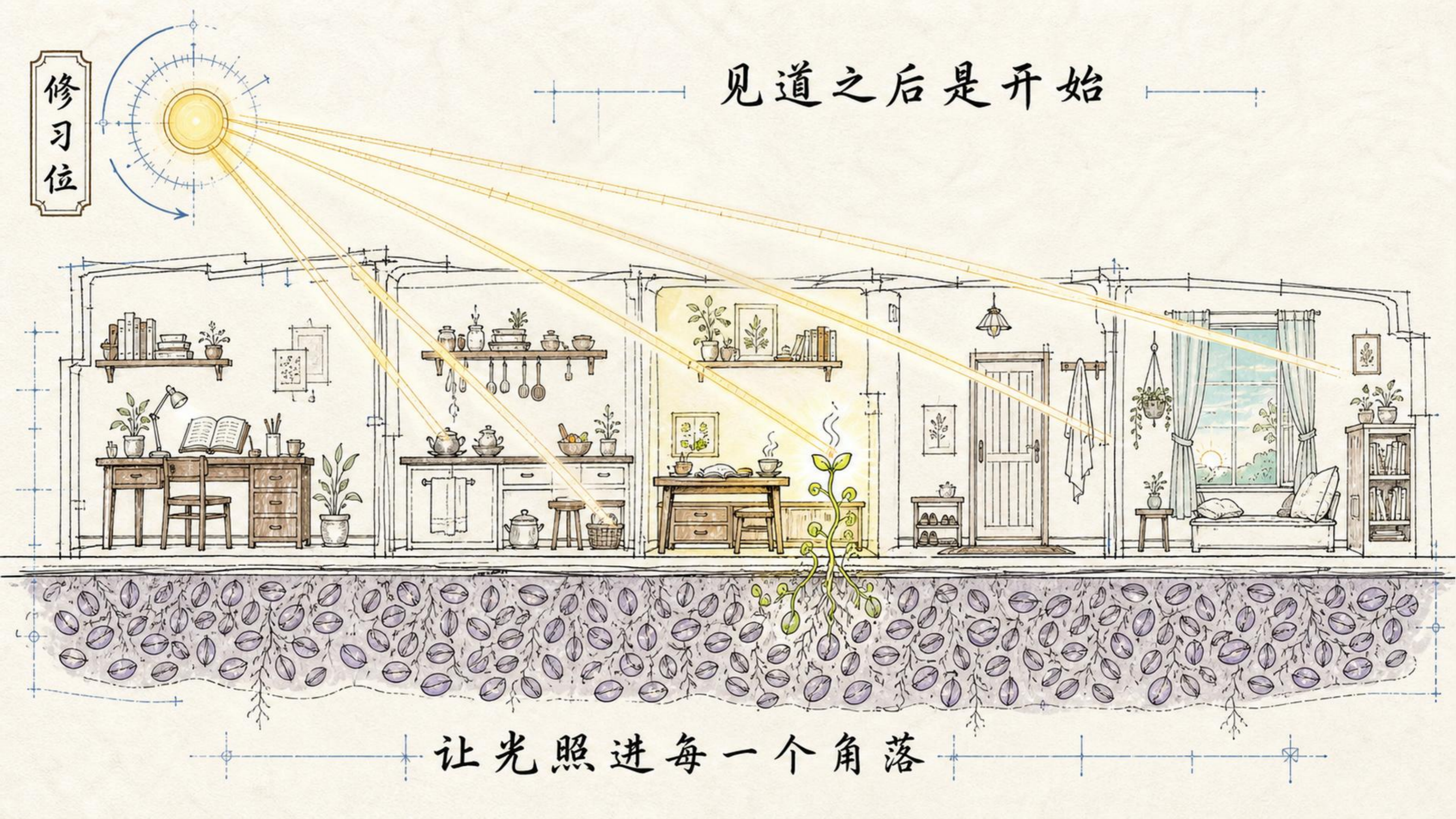

十地

- ①
- ②
- ③
- ④
- ⑤
- ⑥
- ⑦
- ⑧
- ⑨
- ⑩

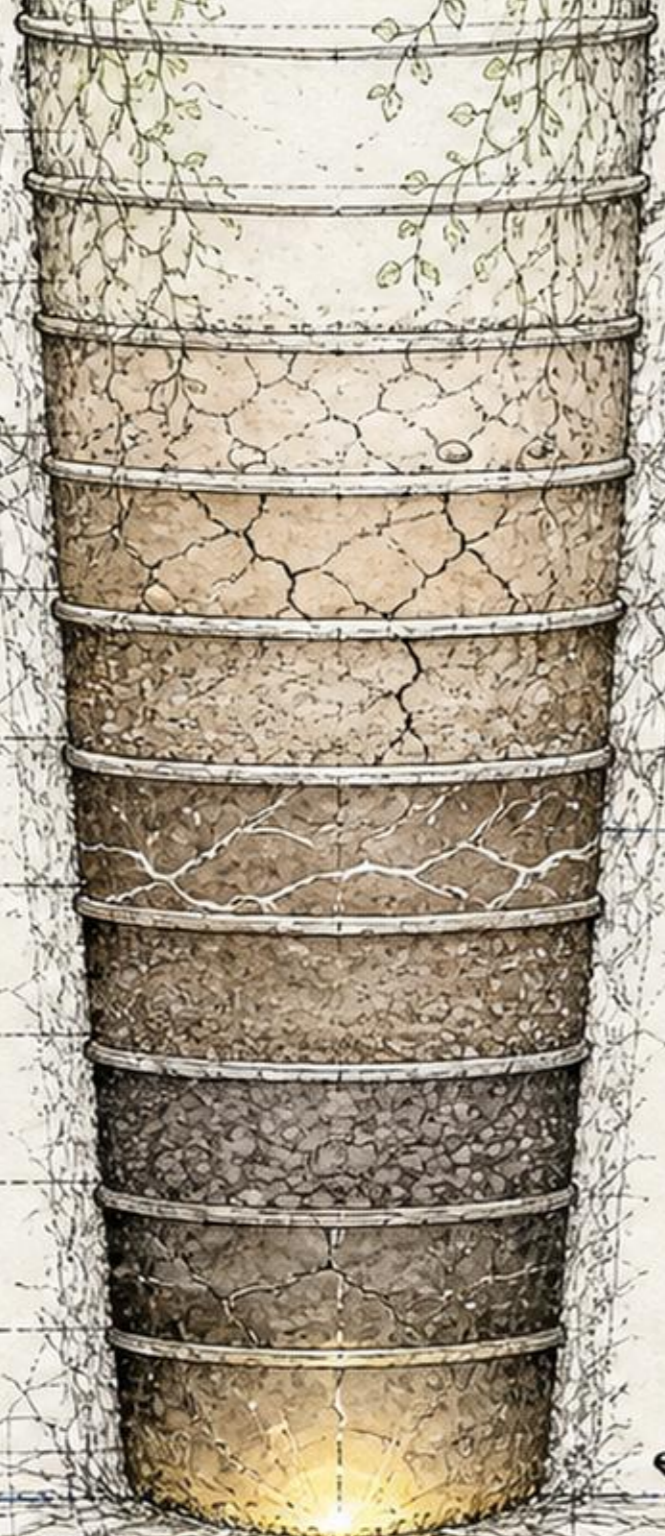

戒了烟，偶尔还想抽

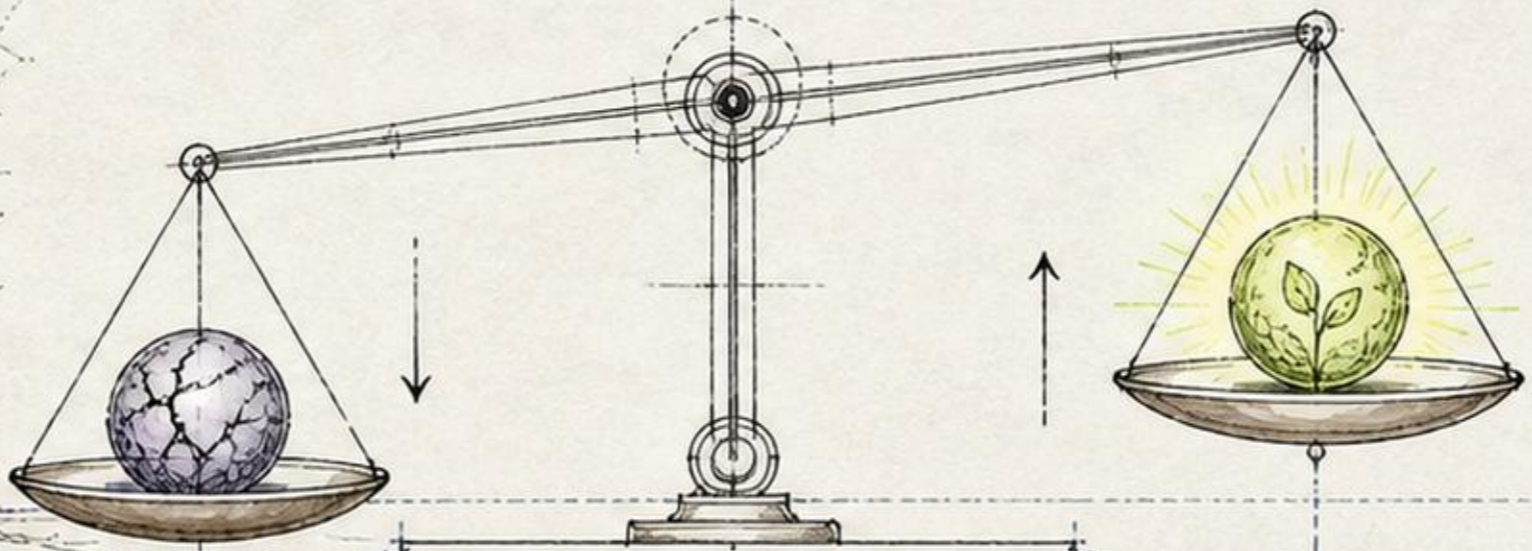

有漏 ↓ 无漏 ↑

八识全转四智

究竟位·佛果

识智本是一体

完工

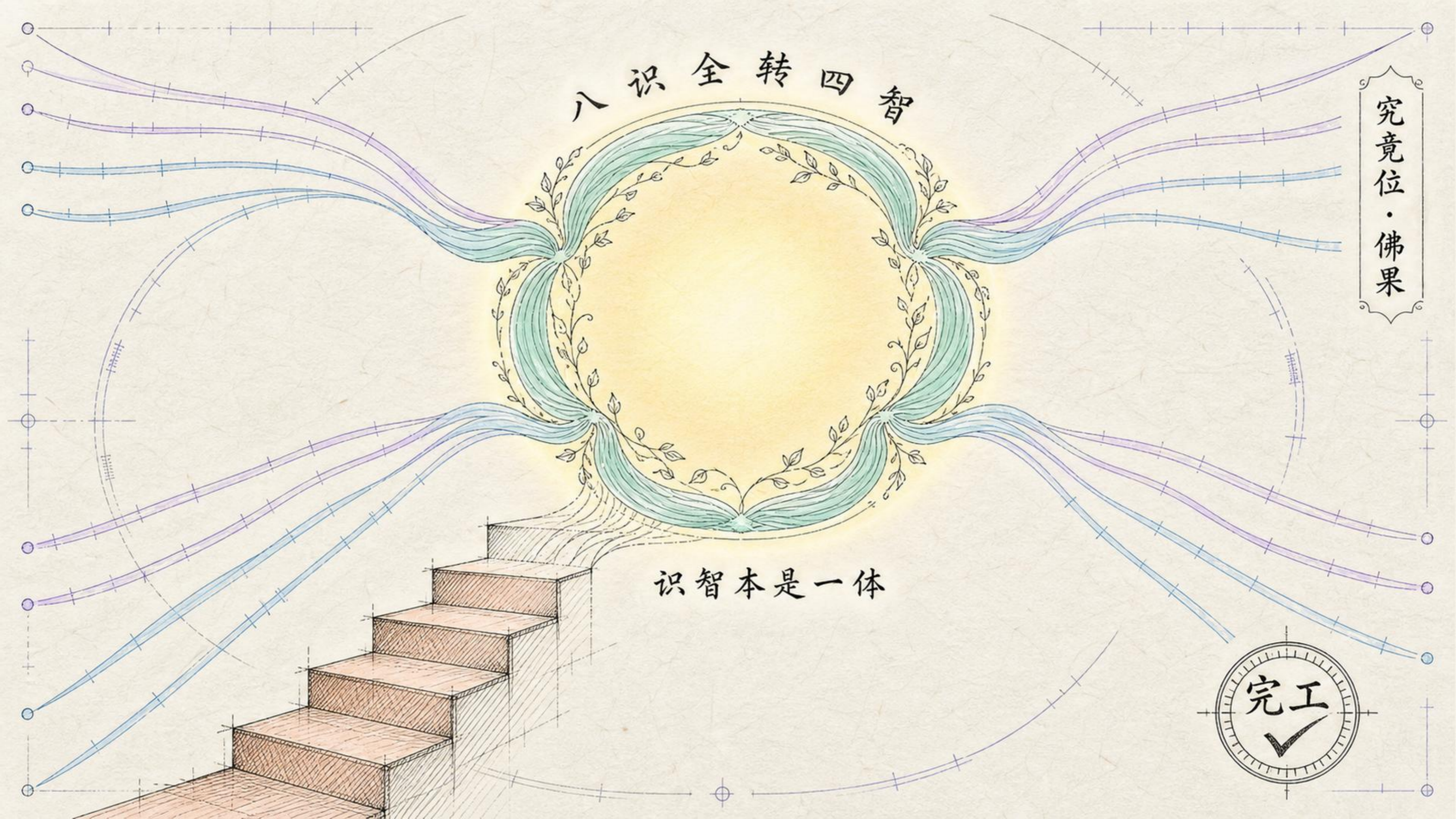

不是消灭，是质变

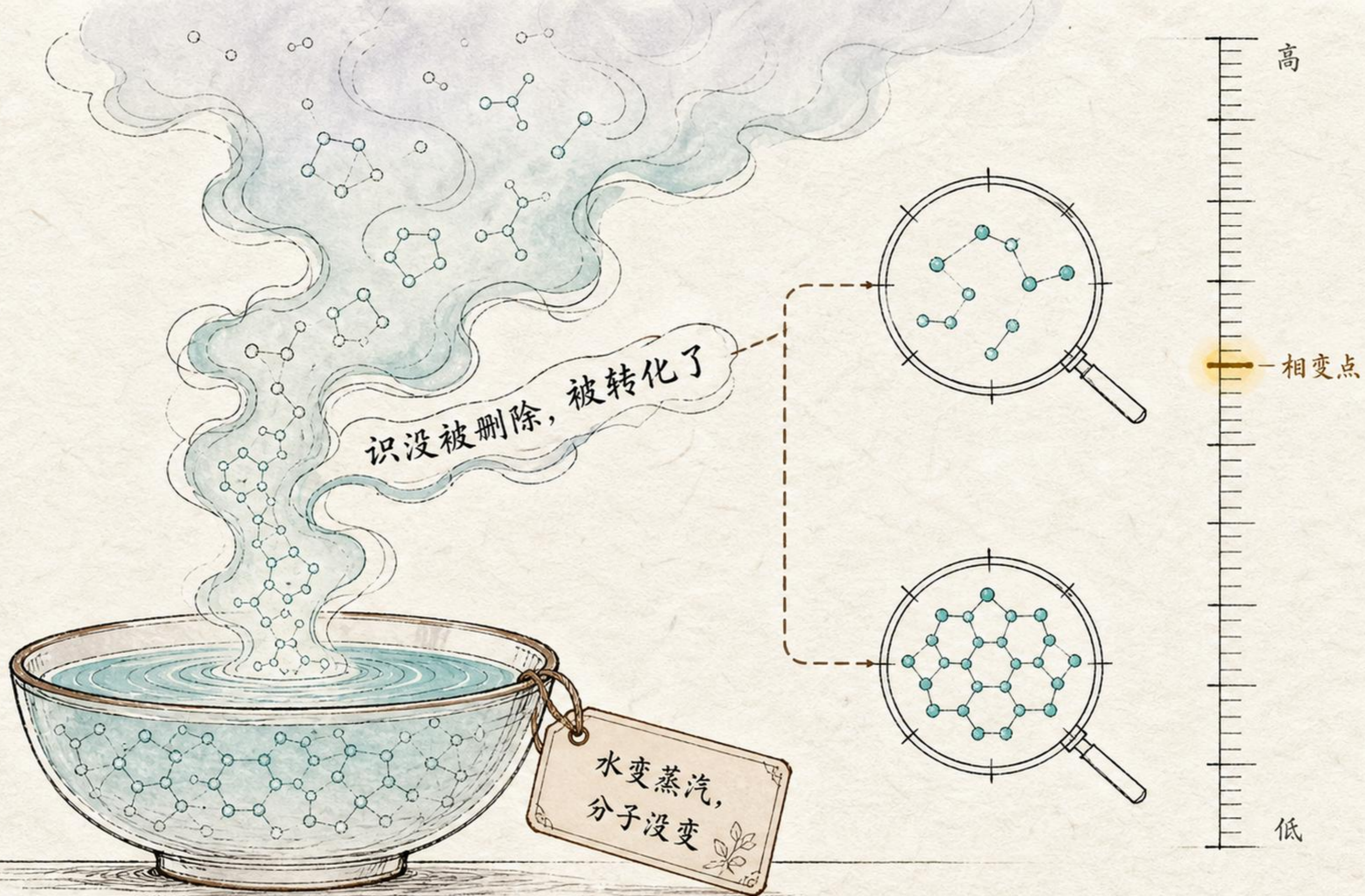

消识显智

消识 · 消解染污模式



显智 · 本有智慧显现

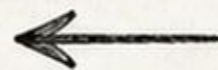

你不缺智慧，
自我系统太吵

看方向，不看距离。



五位不是尺子，是地图

转识
成智

「我」安静了几秒钟

待人更柔软一点点

越来越少被情绪劫持

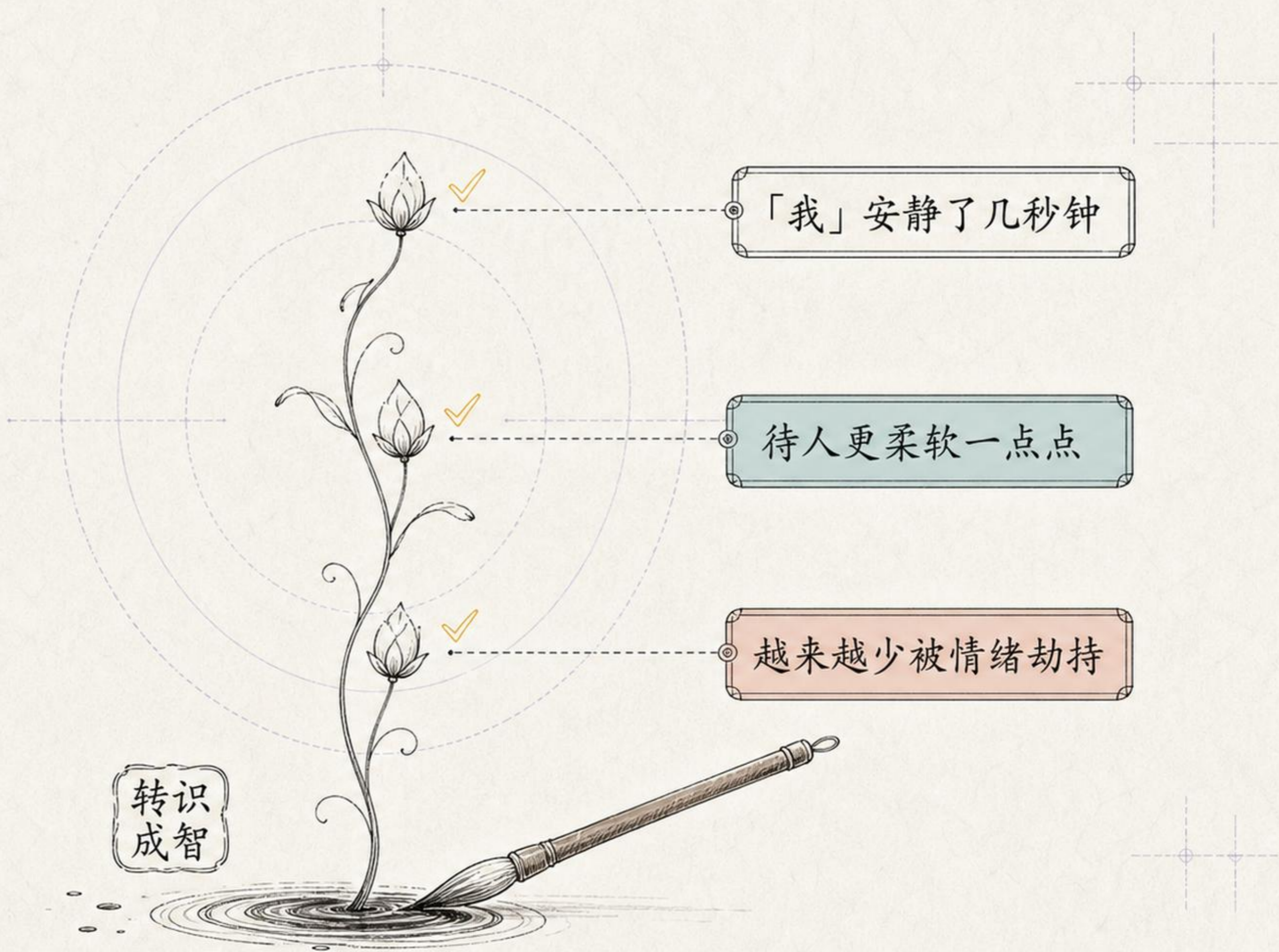

最精密的意识地图

转识成智·五位修行

八识运作机制

种子六条铁律

认知四层结构

180丈

150丈

120丈

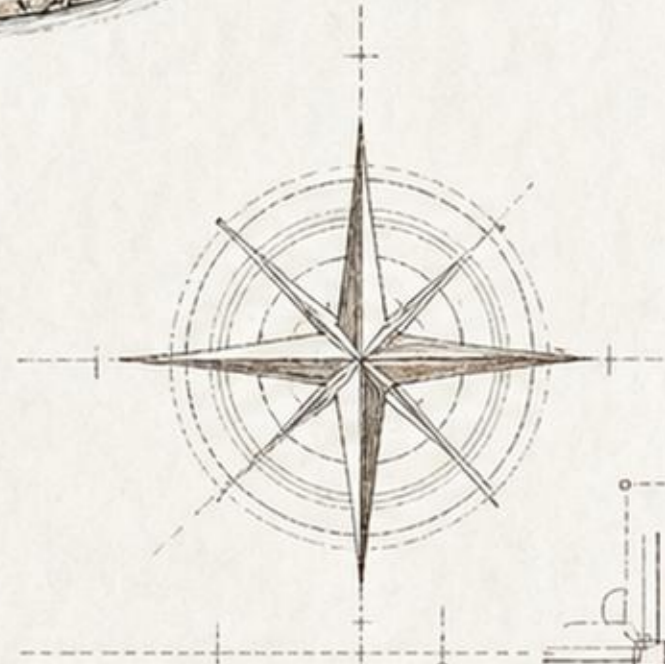
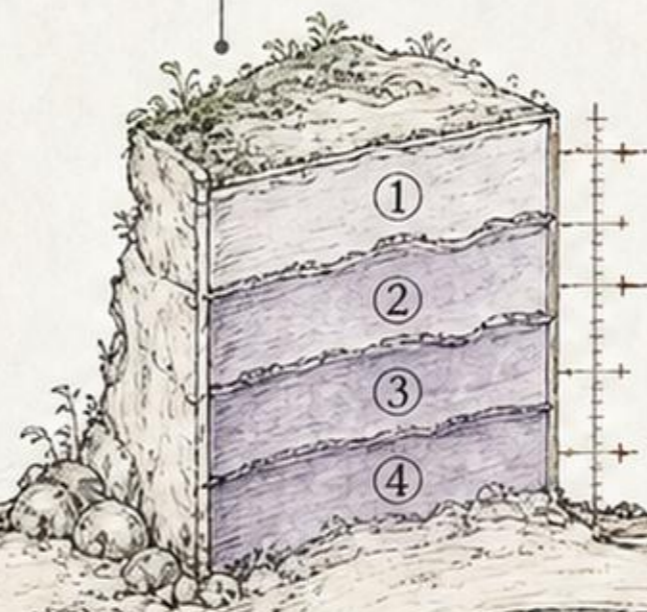
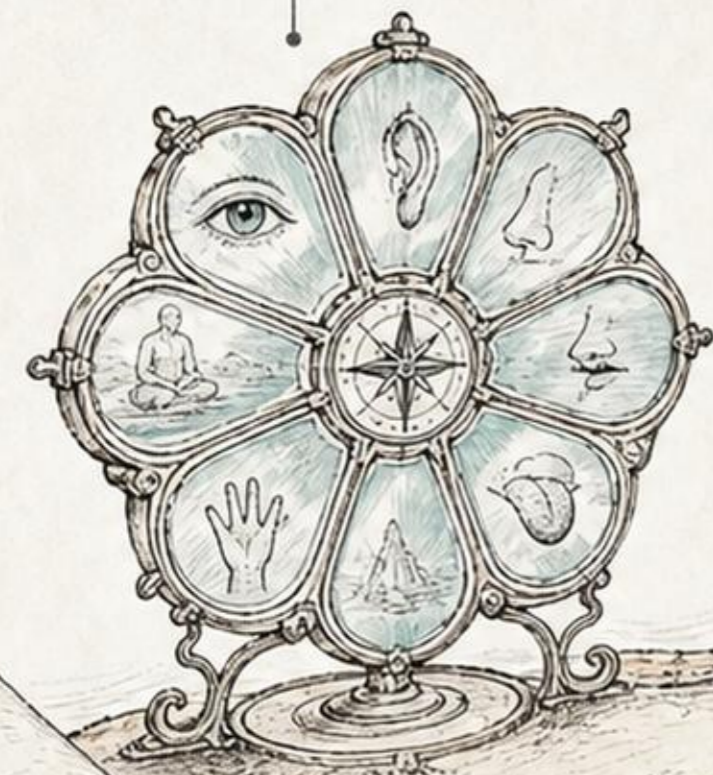
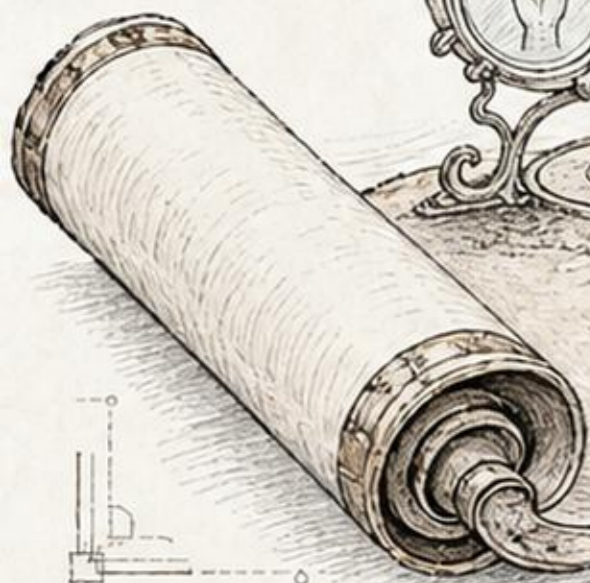

脚手架终归不是大楼

别住在地图里

地图只是地图

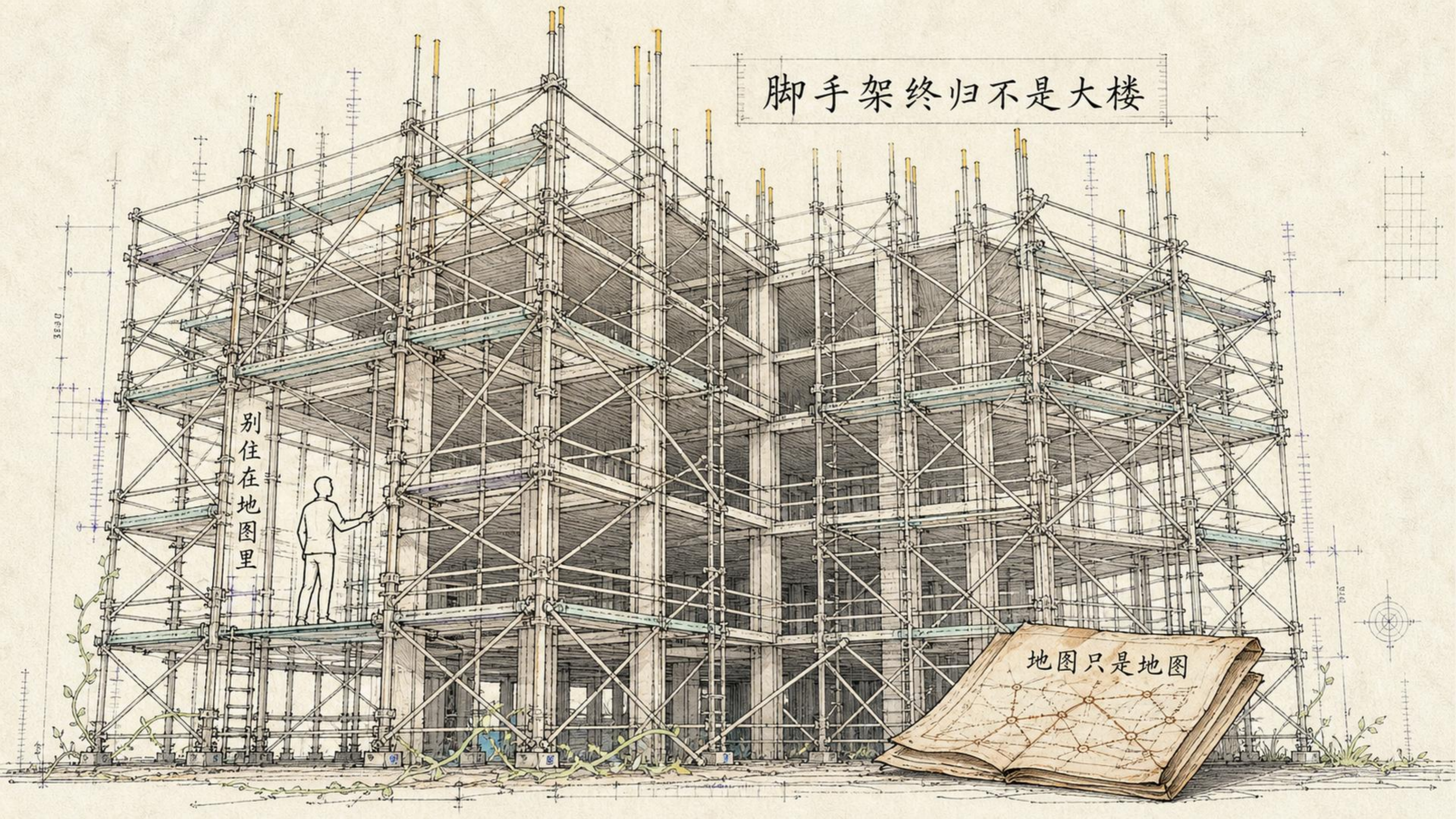

意识工程图纸



挂墙欣赏

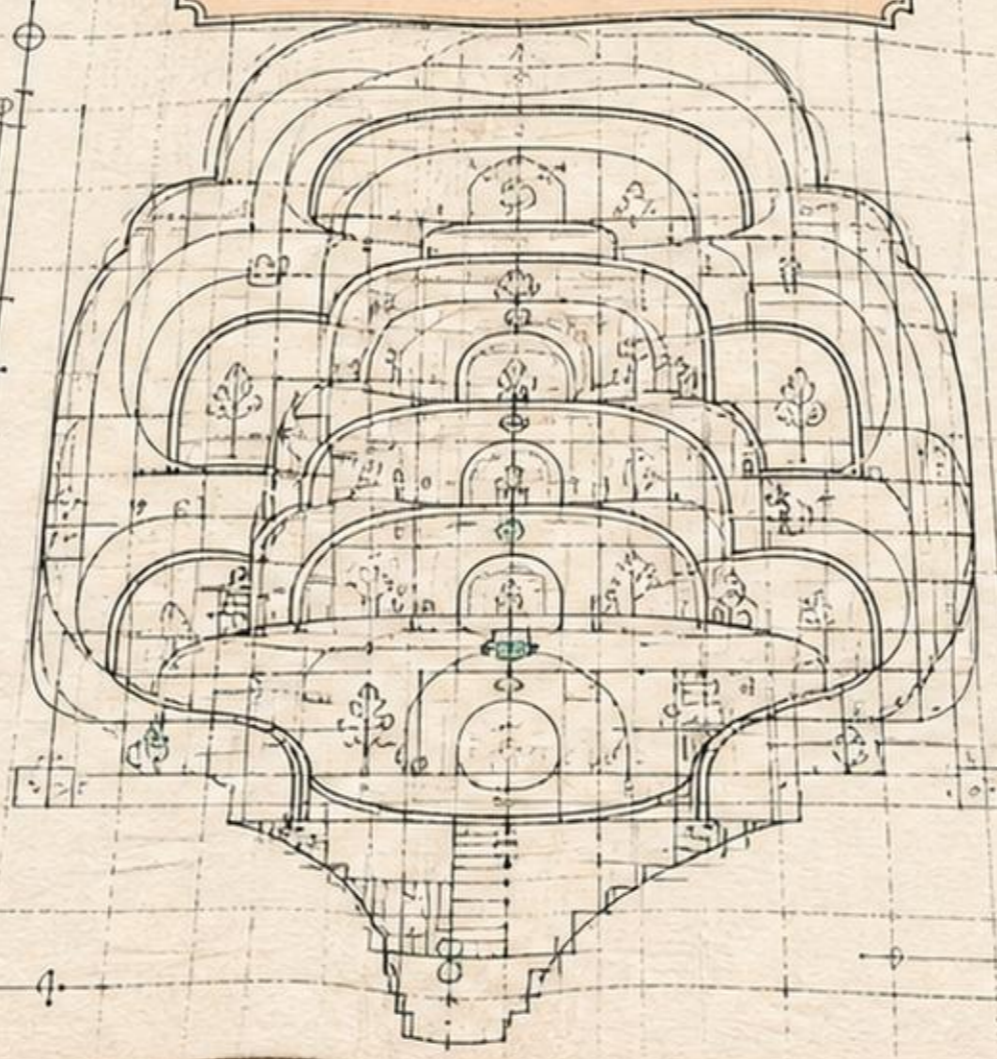

动手改造

你在哪个阶段？

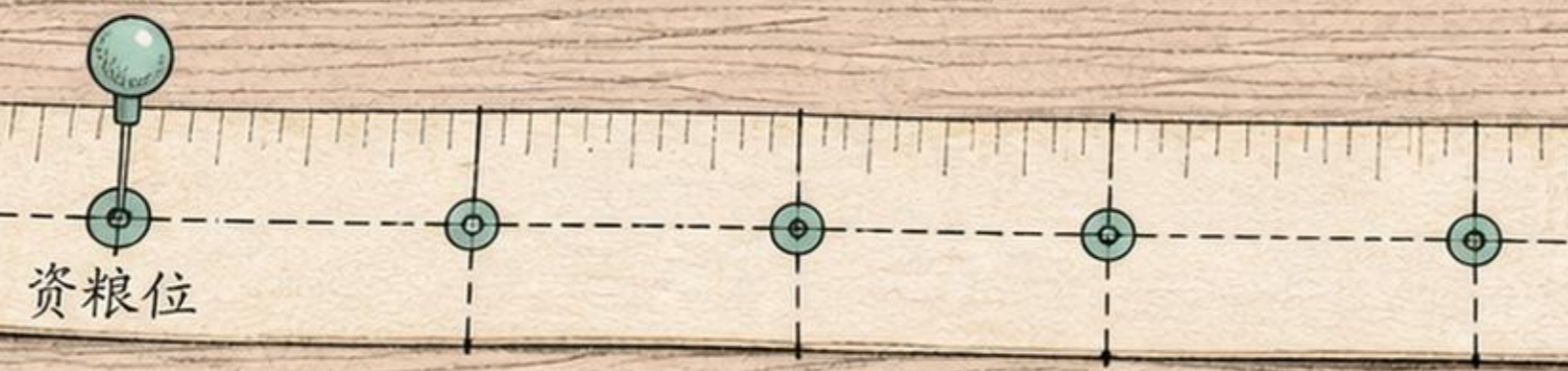

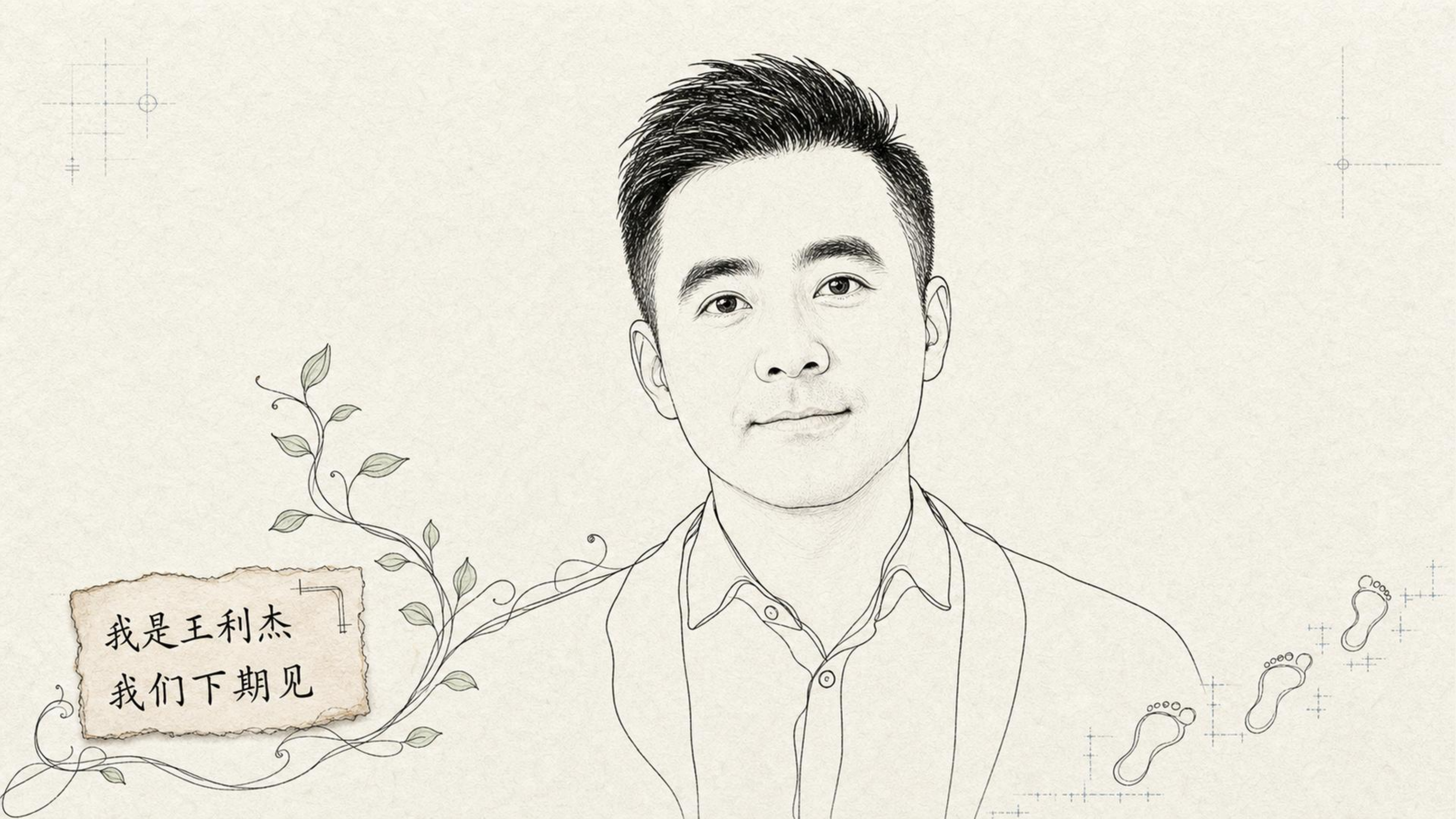

我是王利杰
我们下期见